

Bus System BS 4590 CANopen

Baureihe / Series / Séries
BS 4590

INDEX

1	SAFETY NOTICES	2
1.1	Area of application	2
1.2	Short description	Fehler! Textmarke nicht definiert.
1.3	Start-up (Electronic connection)	2
1.4	Warning notices	2
2	TRANSPORT AND STORAGE	2
3	GENERAL INFORMATION ABOUT FIELD BUS SYSTEMS	3
3.1	Basic characteristics	3
3.2	Bus access and communication of the BS4590 CANopen	3
4	SETTING THE COMMUNICATION PARAMETERS	3
4.1	Manual communication parameter settings	3
4.2	Setting bit rate on the DIP-switch:	4
4.3	Setting node address via CANopen:	4
4.4	Setting bitrate via CANopen:	4
5	CAN-IDENTIFIER /-MESSAGES	4
5.1	PDO Mapping Control and notifier command addresses	5
6	COMMUNICATION CAN OPEN	5
6.1	Build up and wiring	5
6.2	Communication profile	5
6.3	Configuration	6
6.4	Process data objects	6
6.5	PDO-Mapping	6
6.6	Error processing	Fehler! Textmarke nicht definiert.
6.7	Network Boot-Up	7
6.8	Life Guarding	7
6.9	Heartbeat	8
6.10	Heartbeat Producer	8
7	FUNCTION OF THE BS 4590 CANOPEN	9
7.1	CANopen status transitions	9
7.2	Power on	9
7.3	PRE-OPERATIONAL	9
7.4	OPERATIONAL	9
7.5	STOPPED	9
7.6	Emergency Telegramm	9
7.6.1	Error Code	10
7.6.2	Manufacturer-specific Error Code	10
7.6.3	Error Register	10
8	THE BS4590 CANOPEN OBJECT INDEX	11
9	CONNECTION BS4591	12
9.1	View BS 4591	12
9.2	View BS 4591	12

1 Safety notices

1.1 Area of application

RTK actuators are intended for the operation of industrial fittings, like e.g. valves. The manufacturer is not liable for other applications and possibly resulting damages. The applicant carries the sole risk. The adherence to this instruction manual is also part of proper and intended use.

1.2 Short description

The actuators **ST 51xx** are driven by an electric motor and digitally controlled via the Bus interface **BS4591 CANopen**. The Bus interface is built into the motor. The following drives are available with the CANopen Bus interface BS4591.

- **ST5112** **3KN** **linear actuator**
- **ST5113** **6KN** **linear actuator**
- **ST5114/15** **10KN** **linear actuator**
- **ST5106** **15KN** **linear actuator**
- **ST5143** **2,5KN** **damper actuator**

The measurement probe **NI 1321/-22** (level sensor) is supplied with 24V DC and transfers data via the Bus interface **BS4592 CANopen**.

1.3 Start up (Electro connection)

During the operation of electrical devices certain parts are obligatorily under dangerous voltage. Work on electrical units or equipment may only be performed by an electrician or a trained person under instruction and supervision of an electrician according to the electro-technical rules.

1.4 Warning notices

In case of non-adherence to the warning notices massive injuries or material damages may occur. Accordingly qualified personnel must be familiar with all details of this warning according to this instruction manual. Smooth and safe operation requires proper transport, proper storage, set up, assembly, and careful start up. In order to emphasize safety-relevant processes in this operation manual the following safety notices are valid, whereas every notice is marked with an according pictogram.



This sign means: Notice!

„Notice“ marks activities or processes that have an essential influence on the proper operation. In case of non-adherence possible consequential damages may occur.



This sign means: Electrostatic hazardous components!

If this sign is attached to the board there are components there that may be damaged or destroyed through electro static discharges. If components must be touched during setting, measurement, or replacement of boards, discharge is to be provided directly in advance by touching a grounded, metallic surface (e.g. on the casing).



This sign means: Warning!

„Warning“ indicates activities or processes that may cause a safety risk for people or material values if not conducted properly.

2 Transport and Storage

- .Transport to the place of set up in firm packaging.
- .Do not fix lifting devices on the hand wheel.
- .Storage in well-ventilated, dry room.
- .Protection against ground moisture through storage on a shelf or on a wooden grid.
- .Protection against dirt and dust.
- .Treat blank surfaces with an adequate corrosion protection agent.

Regeltechnik Kornwestheim GmbH
Max-Planck-Straße 3
70806 Kornwestheim
GERMANY

Telefon +49 7154 1314-0
Telefax +49 7154 1314-333
Internet www.rtk.de
E-Mail: info@rtk.de

RTK[®]

Choose the Original
Choose Success!

**REGELTECHNIK
KORNWESTHEIM**

A division of CIRCOR International, Inc.

3 General information about the field bus systems

Today, mainly serial field busses are used as communication system for the exchange of information among the automation systems as well as with the connected decentral field devices. In many thousands of successful applications it was impressively proven that the use of field bus technology can achieve cost savings of up to 40% in cabling, start up and maintenance compared to conventional technology. Over only two wires all relevant data like input and output data, parameters, and diagnosis data for the field devices can be transmitted. While in the past often manufacturer-specific, among each other incompatible field busses were used, almost exclusively open, standardized systems are used today. This makes the user independent from individual suppliers and he can select the best and most price-effective product from a large product palette. The area of application includes the manufacturing, process, and building automation.

3.1 Basic characteristics

CANopen determines the technical and functional characteristics of a serial field bus system with which the distributed digital automation devices can be linked to each other. CANopen is designed for fast data exchange in the field level (up to 1 Mbit/s) according to ISO 11898. Here the central control units, like e.g. SPS or PC, communicate over a fast, serial connection with decentral field devices like input/output devices, drives, or sensors. The data exchange with these decentral devices is done asynchronously. Every bus participant can access the bus and transmission messages. The processing of the messages is regulated by priorities.

 The description BS4590 is generally applicable to CANopen devices of the company Regeltechnik Kornwestheim GmbH.

Special functions in 2 device types are differentiated:

1. BS4591 for actuators of the series ST51xx
2. BS4592 for sensors of the series NI13xx

3.2 Bus access and communication of the BS4590 CANopen

- CANopen interface after Full-CAN-2.0B passive with 11 Bit Identifier
- Device profile after CiA DSP401
- Communication profile after CiA DS301 V4.01
- CAN-Bus driver for the support of up to 100 CAN-nodes

4 Setting the communication parameters

4.1 Manual communication parameter setting

The Bus interface BS4590 can be manually configured with DIP switches (no full functionality). The setting of the node address (NodeID) and the setting of the bit rate are possible via the DIP switches with limitations.

The BS4590 is delivered as standard with the node address (NodeID) 1E h (30 decimal). With help of the DIP-switches DIP1 to DIP4 on the module this basic node address can be admitted with an offset in the range from 30 to 44 decimal. The absolute node address is derived as follows:

$$\text{NodeID} = 1\text{Eh} + \text{DIP1} \cdot 2^0 + \text{DIP2} \cdot 2^1 + \text{DIP3} \cdot 2^2 + \text{DIP4} \cdot 2^3$$

with $\text{DIPx}=1$ with closed switch (position ON) and $\text{DIPx}=0$ with open switch.

Example: With closed switch DIP1 and DIP4 the following node address is derived:

$$\text{NodeID} = 1\text{E h} + 1 \cdot 2^0 + 0 \cdot 2^1 + 0 \cdot 2^2 + 1 \cdot 2^3$$

$$\text{NodeID} = 1\text{E h} + 1 \cdot 1 + 1 \cdot 8$$

$$\text{NodeID} = 1\text{E h} + 1 + 8$$

$$\text{NodeID} = 27\text{ h} \quad \text{also address 39 decimal}$$

 The setting 0FH on DIP 1..DIP4 is reserved to set back the BS4590!

Table node address over DIP-switch

		DIP-Switch			
Node address	decimal	DIP4	DIP3	DIP2	DIP1
1E h	30	OFF	OFF	OFF	OFF

Regeltechnik Kornwestheim GmbH
Max-Planck-Straße 3
70806 Kornwestheim
GERMANY

Telefon +49 7154 1314-0
Telefax +49 7154 1314-333
Internet www.rtk.de
E-Mail: info@rtk.de

 **REGELTECHNIK
KORNWESTHEIM**
A division of CIRCOR International, Inc.



1F h	31	OFF	OFF	OFF	ON
20 h	32	OFF	OFF	ON	OFF
21 h	33	OFF	OFF	ON	ON
22 h	34	OFF	ON	OFF	OFF
23 h	35	OFF	ON	OFF	ON
24 h	36	OFF	ON	ON	OFF
25 h	37	OFF	ON	ON	ON
26 h	38	ON	OFF	OFF	OFF
27 h	39	ON	OFF	OFF	ON
28 h	40	ON	OFF	ON	OFF
29 h	41	ON	OFF	ON	ON
29 h	42	ON	ON	OFF	OFF
2B h	43	ON	ON	OFF	ON
2C h	44	ON	ON	ON	OFF
Reserved	general RESET	ON	ON	ON	ON

4.2 Setting bit rate on the DIP-switch:

The setting of the bit rate is done with the help of the DIP-switch DIP5 and DIP6 on the module. The following bit rates are possible:

Bit rate kBit/s	DIP5	DIP6
20	ON	OFF
250	OFF	OFF
500	OFF	ON
1000	ON	ON

4.3 Setting the node address over CANopen:

The BS4590 may receive an optional node address in the range from 1...127 (01H..07FH) via LSS-service (Layer Setting Services to Protocol, CiA DSP 305) via CANopen. After that the settings of a of a node address on a DIP-switch are no longer relevant. The adjustment of the NodeID via LSS results in a restoration of the OD with default values.

 Default setting: 1E h (30 decimal)

4.4 Setting the bit rate over CANopen:

The BS 4590 may receive a bit rate over CANopen via LSS- service (Layer Setting Service and Protocol, CiA DSP-305). After that the settings of a bit rate on the DIP switch are no longer relevant. The bit rate 800kBit/s is not supported.

Index in LSS Timing Table	Bit rate kBit/s
0	1000
2	500
3	250
4	125
5	100
6	50
7	20
8	10

 Default setting: 250Kbit/s

5 CAN-Identifier /-Messages

For every CAN-message with process data (process-data-object,PDO) a specific CAN-Identifier is assigned according to CiA Draft Standard 301 V4.x. The CAN-Identifiers for input and output data are derived from the node address.

Regeltechnik Kornwestheim GmbH
 Max-Planck-Straße 3
 70806 Kornwestheim
 GERMANY

Telefon +49 7154 1314-0
 Telefax +49 7154 1314-333
 Internet www.rtk.de
 E-Mail: info@rtk.de



**REGELTECHNIK
 KORNWESTHEIM**
 A division of CIRCOR International, Inc.

5.1 PDO Mapping Control and notifier command addresses

A PDO can transport a maximum of 8 Bytes. The assignment of variables to PDO's is defined over the following Mapping Tables. The BS 4590 uses only 1 byte for digital inputs and outputs, as well as for analogous values.

BS 4591 for ST51xx drives

Object	Signal	Resulting COB-ID hex	Resulting COB-ID decimal	Usage data decimal 1 byte
EMERGENCY	Status	01H+Module-ID	128-254	
1.Tx PDO	Final position open reached	180H+Module-ID	384-510	11111110
1.Tx PDO	Final position close reached	180H+Module-ID	384-510	11111101
2.Tx PDO	Analogue value Potentiometer	280H+Module-ID	640-766	0-255
1.Rx PDO	Drive "STOP"	200H+Module-ID	512-639	00000000
1.Rx PDO	Drive "OPEN"	200H+Module-ID	512-639	00000001
1.Rx PDO	Drive "CLOSE"	200H+Module-ID	512-639	00000010

^

BS 4592 for NI1321 level measurement probe

Object	Signal	Resulting COB-ID hex	Resulting COB-ID decimal	Usage data decimal byte1
EMERGENCY	Status	01H+Module-ID	128-254	
2.Tx PDO	Analogue value NI1321	280H+Module-ID	640-766	0-255

6 Communication CAN open

6.1 Build up and wiring

A drilled, shielded double-wire line is used as CAN-Bus-cable that is closed on both ends with 120ohm. The shield is to be lain one-sidedly on PE. The wave resistance of the cable shall be 120ohm. The diameter is based on the line length.

Line length [m]	Max. bit rate [kBit/s]	Specific resistance [m./m]	Line diameter [mm ²]
0 ... 40	1000	70	0,25 ... 0,34
40 ... 100	500	<60	0,34 ... 0,60
100 ... 500	100	<40	0,50 ... 0,60
500 ... 1000	20	<26	0,75 ... 0,80

Recommended line parameters

6.2 Communication profile

The interface between application and device is clearly defined by a uniform communication profile. The communication profile describes the different communication objects and services and the available modes of the trigger for sending messages. The communication model supports the transmission of the synchronous and asynchronous sending. Network wide, coordinated data exchange is possible with the means of synchronous message transmission. The synchronous transmission is initiated with the pre-defined object SYNC-message. Asynchronous messages can be transmitted anytime.

6.3 Configuration

Service data objects

The network management accesses the communication and device profile of the network participants. Service data objects (SDO) are available for these accesses. The SDO pose to be a dot-to-dot connection for the access to the object index of the network node. The access takes place according to the Multiplexed Domain Protocol, whereas the index and sub index of the addressed object are used as Multiplexor. This protocol is based on receipt operation. Messages that are shorter than 5 byte can be transmitted with one sending/receipt. The owner of the object index is the SDO-server. The reading and writing accesses over SDO's are supervised by the CANopen device and checked for validity. There are a number of access restrictions like *read only*, *write only*, *no pdo mapping*. Error messages give detailed information about access conflicts. SDO's mainly serve configuration purposes.

6.4 Process data objects

The data exchange does not require a Bus master. The process data exchange in real-time between the nodes takes place over process data objects (PDO) directly and without protocol overhead. A PDO is a CAN-message whose data content, identifier, inhibit time, transmitting type, and event timer can be configured over entries in the object index via SDO's. The entries for receipt objects are under index

[1400H] and under [1800H] for sending objects. CANopen allows cyclic and event-controlled communication.

The transmitting type states the manner of reaction to the SYNC-message, the inhibit time is the minimum time that must go by between two sending of the PDO. This way it is possible to reduce the Bus load to a minimum and achieve a high data flow rate. The event timer is used if a device is to send a PDO in regular, even intervals. The inhibit time is not considered in this transmission type. Further there is the option of inquiring PDO's over remote frames. A simple device usually supports four PDO's. These are initialised with pre-set identifiers. Further PDO's can be intended on the device, but be set invalid to avoid conflicts. This is done by setting the MSB (Bit 31) in the identifier of the PDO. The identifier can be reached in the object index under the entry communication parameter, sub index 1. Bit 30 states 0 as the value that remote requests are allowed for this PDO. Bit 29 on 0 stands for 11-Bit Identifier.

Bit	31	30	29	28-11	10-0
11-Bit ID	0/1	0/1	0	000000000000000000	11-Bit Identifier
29-Bit ID	0/1	0/1	1	29-Bit Identifier	

Structure of the COB-Identifiers

The transmission types on Sub index 2 can be set in the range from 0 to 255. The values 0 to 240 mean that the transmission of the PDO stands in relation to the SYNCMessage. 0 means that probed input values are only sent in case of change upon receipt of the SYNC, between 1 and 240 means that the PDO is sent after the receipt of the according number of SYNC. The values 241 to 251 are reserved. The types 252 and 253 are only intended for remote objects. At 253 the data is updated upon receiving the remote request. 254 and 255 stand for asynchronous PDO, whose triggering is manufacturer or device specific. The inhibit time is saved in 100µs - steps as unsigned16-value on sub index 3. Sub index 4 states the CMS- priority group. This mechanism is omitted with the introduction of the CiA DS301 V4.x. The sub index 4 is maintained for compatibility reasons and is marked as reserved. The entry has no influence on the function. Sub index 5 contains the event timer. It is saved in 1ms steps as unsigned16-value. In dependency of the supported sub indexes sub index 0 must be set to the according value (5). The following rules are valid for PDO's in the I/O Profile:

The first sending and receipt-PDO is used for the exchange of digital data, the second sending and receipt PDO for the exchange of analogous data. If a device does not support digital in or outputs, the first sending and receipt PDO shall remain unused. On devices without analogous interface components the second sending and receipt PDO shall not be used.

6.5 PDO-Mapping

Every communication parameter entry of a PDO includes a Mapping entry that is located higher in the object index 200H. This mapping table corresponds to the content of the data of the PDO. The basis for the mapping is that there are variables in the object index that are mappable, for example digital entries on index [6000H] and digital outputs on Index [6200H]. Of course, these values can be set and read over SDO. To use the advantages of the CAN-busses, the variables are shown in PDO. This happens as follows:

The entries in the mapping table are four bytes in size. The number of mappable objects is written on sub index 0.

On every following sub index a reference to the index and sub index of the variable and its length in bit is saved, for example 6000108H for a reference to index [6000H], sub index 1, length 8 Bit. In this case the value of the digital input is shown on the first byte of a sending PDO.

In most devices, the mapping is done with a granularity of 8, meaning there is a maximum of 8 possible entries to one byte of the mapping table. Sometime it may make sense to exclude areas from the mapping.

For example, a device should only evaluate the 5th byte of a PDO. In this case 2 unsigned16 Dummy-objects can be entered in the mapping, insofar supported by the device. With help of the mapping table the PDO to be sent is coded or the received PDO is decoded according to the set communication parameters.

6.6 Error processing

Every node in the net is able to signal errors insofar they are recognized by the hardware and software. The emergency software is used for this purpose. Internal fatal error conditions are coded in error codes and sent to the other nodes only once. If further other errors occur, the node remains in the error condition and sends a new emergency object. If the error is eliminated, the node sends an error notice with the code "No Error". The emergency-messages consist of 8 bytes,

whereas the first and second byte are additional information that can be found in the device profile. The third byte is the content of the error register, and the remaining 5 bytes are manufacturer-specific. The Emergency Error Code is saved in object [1003H], the *Pre-Defined-Error-Field*. It is an error logbook, the errors are sorted by time. The oldest error is on the highest sub index.

Byte	0	1	2	3	4	5	6	7
Content	Emergency Error Code		Error Register, Object [1001H]	Manufacturer Specific Error Field				

Structure of the Emergency-message

6.7 Network Boot-Up

The NMT-Master is responsible for the booting of the network. The booting is done in several steps. Depending on the type of connected devices the identifiers on minimum devices are defined over pre-defined settings. The pre-defined settings for the identifiers for Emergency, PDO's and SDO's are calculated from the node address that may lie between 1 and 127, added to a basis identifier that determines the function.

Bit	10										0
COB-Identifier											0
	Function code					Module-ID					

Determination of the COB-Identifier from the node address

Object	Resulting COB-ID hex	Resulting COB-ID decimal
Nodeguard/ Heartbeat/ Bootup	700H+Module-ID	1792-1918

The configuration data can be loaded onto the device with the pre-defined SDO. After the device was set to the NMT status "OPERATIONAL" with the NMT-service *Start_Remote_Node* from the NMT-status "PRE-OPERATIONAL", PDOs can be sent. The minimum device also supports the services

Stop_Remote_Node, *Enter_Pre-Operational_State*, *Reset_Node*, *Reset_Communication*. After turning on and initialisation the device automatically goes into the status "OPERATIONAL". With *Reset_Node* the device is set back completely, *Reset_Communication* effects a reset of the communication parameters.

6.8 Life Guarding

The optional node supervision is achieved through the so-called *Life Guarding*. The NMT-Master sends a cyclic Lifeguard-message to the device. It answers with a message that contains its current NMT-status and a bit changing between two messages. Upon lack of answer or unexpected NMT-status of the device the NMT-Master application is informed. Further the device can detect the failure of the Master. The *Life Guarding* is started with the first sending of the Master.

 In the BS4591 the drives are driven to closing position in case of error (e.g. Bus failure)

6.9 Heartbeat

The Heartbeat is, analogous to Life Guarding, a supervision service that however does not need a NMT-Master. The tasks of Producer and Consumer can be conducted by all CANopen devices that support this service.

6.10 Heartbeat Producer

The Heartbeat Producer sends a cyclic Heartbeat message. The Producer Heartbeat Time (unsigned 16-bit value in ms) set on the index [1017H] is used as interval time. If this time expires, a message with the following structure is sent:

11-bit CAN Identifier	1 Byte usage data
700H+NodeID	Producer state

Table 13 : Structure of the Heartbeat-message

The used COB-ID is the 0700H + node number. The Heartbeat-Producer states his NMT status (producer state) in the first byte of the message. It can assume the following values:

00H BOOTUP
 04h STOPPED
 05h OPERATIONAL
 7Fh PRE-OPERATIONAL

 The Heartbeat-Producer is deactivated if the value zero is entered as Producer Heartbeat Time!

7 Function of the BS 4590 CANopen

7.1 CANopen Status transitions

The NMT-message for changing the device status has the following structure:

11-bit CAN Identifier	2 Byte usage data	
0	cs	NODE_ID

NODE_ID Node address ;

NODE_ID = 0 addresses all components (Broadcast)

Cs Command

The *Table* summarizes all NMT-Master telegrams for status control of the CANopen device.

Command Cs	Designation	Function	NMT-Status after performance
1 (01H)	Start_Remote_Node	Starts the device and the PDO-transmission releases outputs	OPERATIONAL
2 (02H)	Stopp_Remote_Node	Stops PDO-transmission turns off outputs	STOPPED
128 (80H)	Enter_Pre_Operational_State	Stops the PDO-transmission, SDO still active	PRE-OPERATIONAL
129 (81H)	Reset_Node	Conducts a reset of the device; Cold start The device is set back to its default values	PRE-OPERATIONAL
130 (82H)	Reset_Communication	The communication parameters are set back to their default values	PRE-OPERATIONAL

NMT- Master telegrams for status control

7.2 Power on

After "Power-On" the device conducts the required initialisations and switches to status "OPERATIONAL".

 Should there be no Bus connection to the Master the faulty behaviour is activated in the BS4591. The drive goes to closed position.

BY sending the Start_Remote Signals the respective slave can then be set to „Operational“ status again.

7.3 PRE-OPERATIONAL

In this status no process-data-objects (PDO's) are active. The Default-Identifiers for the Service-Data-Objects (SDO's) are available. All necessary configurations can be conducted over SDO. After completion of the configuration the device can be set to the status "OPERATIONAL". This is done by the NMT-Master or by the user via a network configurator.

7.4 OPERATIONAL

In the status "OPERATIONAL" process data objects can be exchanged. An access via SDO's is also possible.

7.5 STOPPED

The communication is stopped in whole in the status "STOPPED". This is not applicable for a possible activated node guarding, it is still functional. Further this status can be used to bring the application into a „Safety status“. In this condition no PDO-, SDO-, SYNC- and Emergency- communication functions. The status can be left again via an NMT-Message.

7.6 Emergency Telegram

The status of the CANopen Chip164 is transmitted via high priority emergency telegrams in case of error. These

Regeltechnik Kornwestheim GmbH
Max-Planck-SträBe 3
70806 Kornwestheim
GERMANY

Telefon +49 7154 1314-0
Telefax +49 7154 1314-333
Internet www.rtk.de
E-Mail: info@rtk.de

RTK[®]

 Choose the Original
Choose Success!

**REGELTECHNIK
KORNWESTHEIM**
A division of CHROOR International, Inc.

telegrams have data length of 8 Bytes and contain error information. The Emergency Telegram is transmitted as soon as one of the signalled errors occurred. The specific Emergency Telegram is always only transmitted once, even if the telegram occurs over a longer period of time. If all error reasons are eliminated, an Emergency Telegram with content 0 (error eliminated) is again transmitted. The structure of the Emergency Telegram (8 Byte data) is illustrated hereafter:

Byte	0	1	2	3	4	5	6	7
	Error Code		Error Register, Object [1001H]	Manufacturer specific Error Code				

Emergency Telegram (Byte-Field)

7.6.1 Error Code

The Error Code (Byte field 0+1, LSB, MSB) shows whether an error is present, or whether the error is already eliminated (no error). The following error codes may occur:

0000H	no error
1000H	global error
6100H	internal software error
6101H	internal Tx Puffer overflowed (Bus load too high, or message priority is too low)
6102H	internal Rx Puffer overflowed (Bus load too high)
8110H	CAN-message lost upon receipt (Bus load too high)
8120H	Device is in error passive mode
8130H	Lifeguard or Heartbeat error Upon Heartbeat Consumer-error the node address of the failed device is transmitted in the manufacturer specific part (Byte 3).
8140H	Device had recognized CAN-BUSOFF
0FF00H	Device specific error (see Chapter 7.8)

7.6.2 Manufacturer specific Error Code

The manufacturer specific Error Code is shown in Byte 3.

0	no error
1	EEPROM-error (hardware error during reading/writing or the configuration in the non-volatile memory)
2	Watchdogtimer triggered (software or RAM/ROM-error)
3	Error during DefineVariable (Software or RAM- error)
4	Error during PutObj (Software or RAM- error)
5	Error during processing of the OD-access rights (Software or RAM- error)
6	false configuration
7	false node address

7.6.3 Error Register

The Error Register (Byte field 2) can take on the following values:

81H:	a manufacturer specific error occurred.
11H:	CAN-Communication error
01H:	a general error occurred
00H:	there no longer is an error – error reset

8 The BS4590 CANopen Object Index

Index [hex]	Object	Name	Data type	Available
1000	Var	Device Type	Unsigned32	BS4591/92
1001	Array	Error Register	Unsigned8	BS4591/92
1003	Array	Error Message	Unsigned32	BS4591/92
1005	Var	Identifier SYNC-message	Unsigned32	BS4591/92
1007	Var	SYNC window length	Unsigned32	BS4591/92
1008	Var	Device designation	String	BS4591/92
1009	Var	Hardware Version	String	BS4591/92
100A	Var	Software Version	String	BS4591/92
100C	Var	Var Guard Time	Unsigned16	BS4591/92
100D	Var	Life Time Factor	Unsigned8	BS4591/92
1010	Array	User-Parameter save	Unsigned32	BS4591/92
1011	Array	Default-Parameter reload	Unsigned32	BS4591/92
1014	Var	Identifier Emergency	Unsigned32	BS4591/92
1016	Array	Consumer Heartbeat Time	Unsigned32	BS4591/92
1017	Var	Producer Heartbeat Time	Unsigned16	BS4591/92
1018	Record	Identity Object	Identity	BS4591/92
Index [hex]	Object	Name	Data type	Available
1200	Record	1 st Server SDO Parameter	SDO Parameter	BS4591/92
1201	Record	2 nd Server SDO Parameter	SDO Parameter	BS4591/92
1400	Record	RxPDO1 Communication parameter Digital Output	PDOComPar	BS4591 (Relay)
1600	Record	RxPDO1 Mapping parameter Digital Output	PDOMapping	BS4591 (Relay)
1800	Record	TxPDO1 Communication parameter Digital Input	PDOComPar	BS4591 (final position message)
1801	Record	TxPDO2 Communication parameter Analogue Input	PDOComPar	BS4591/92 (Analogue values)
1A00	Record	TxPD01 Mapping parameter Digital Input	PDOMapping	BS4591 (final position message)
1A02	Record	TxPD02 Mapping parameter Analogue Input	PDOMapping	BS4591/92 (Analogue values)
2000	Var	I/O Configuration	Unsigned8	BS4591/92
6000	Array	PDO Digital Input	Unsigned8	BS4591
6200	Array	PDO Digital Output	Unsigned8	BS4591
6206	Array	Error Mode Digital Output	Unsigned8	BS4591/92
6207	Array	Error State Digital Output	Unsigned8	BS4591/92
6401	Record	PDO Analogue Input	Integer16	BS4591/92

Object indexes (Object Dictionary of the BS4590)

9 Connection BS4591

9.1 View BS 4591

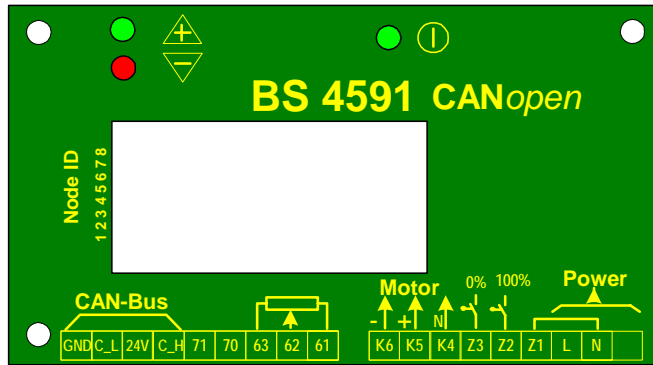

9.2 View BS 4591

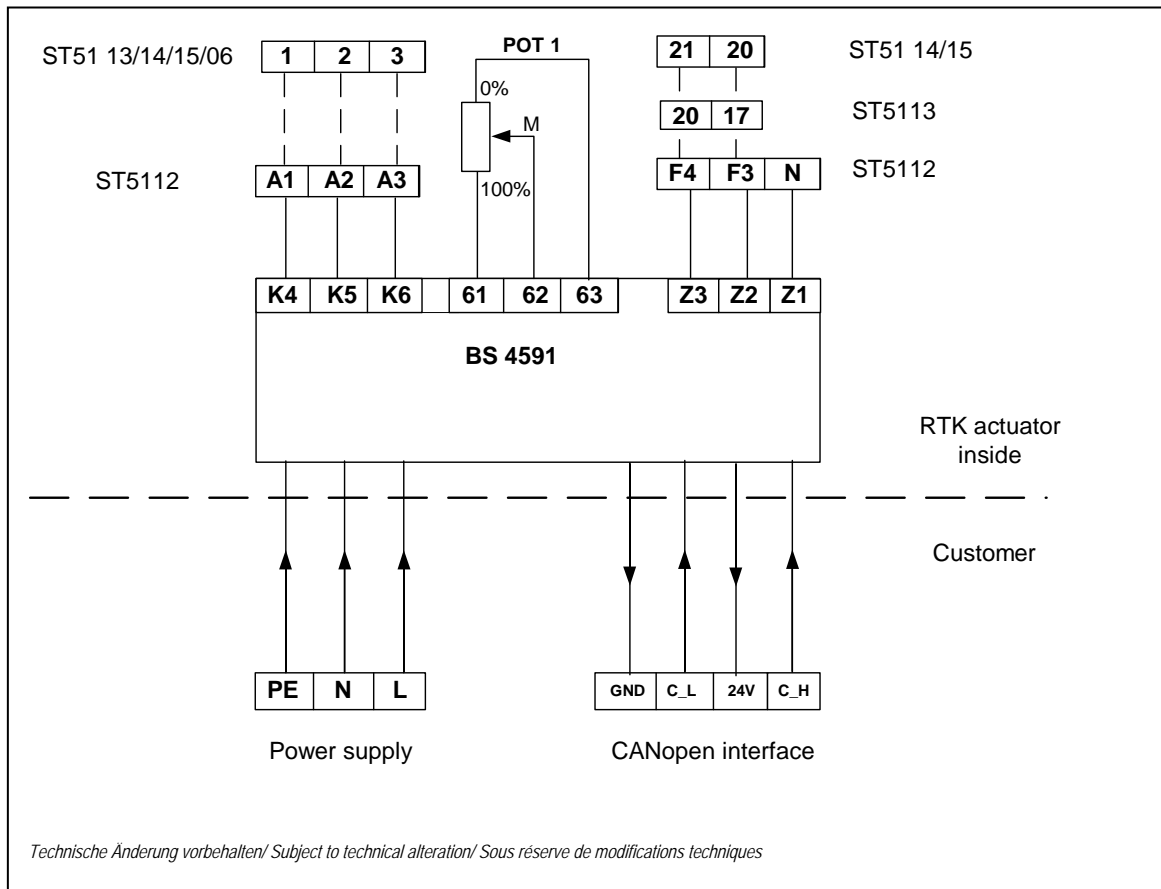

Regeltechnik Kornwestheim GmbH
 Max-Planck-Straße 3
 70806 Kornwestheim
 GERMANY

Telefon +49 7154 1314-0
 Telefax +49 7154 1314-333
 Internet www.rtk.de
 E-Mail: info@rtk.de



**REGELTECHNIK
 KORNWESTHEIM**

A division of CIRCOR International, Inc.