

Installation, Operation and Maintenance Manual

General Stem-Guided Control Valves

NPS ½ - 12 (DN 15 - 300)

CL 150 - 900 (PN 16 - 160)

www.rtk.de



Contents

List of Figures.....	4
List of Tables.....	6
1 General Information	7
2 Safety Terms	7
3 Unpacking.....	7
4 Installation.....	8
4.1 Installation Space	8
4.2 End Caps	8
4.3 Cleaning the line.....	8
4.4 Installation Position.....	8
4.5 Flow Direction	8
4.6 Tension on Valve Body	8
4.7 Welding the Valve In-line	8
4.8 Piping Arrangement	8
4.9 Actuator Mounting.....	8
4.10 Electrical Connection.....	8
4.11 Pneumatic Connection	8
5 Commissioning	9
6 Valve Maintenance	9
7 Valve Disassembly and Reassembly	11
7.1 Remove the Actuator	13
7.2 Disassemble the Valve.....	13
7.2.1 2-Way Standard Valves	13
7.2.2 2-Way QCS (Quick Change Seat) Valves.....	13
7.2.3 3-Way Mixing Valves.....	13
7.2.4 3-Way Diverting Valves	13
7.3 Replacing the Valve Trim.....	14
7.4 Lapping the Valve Trim.....	14
7.5 Replacing the Packing.....	14
7.5.1 PTFE/Graphite and Pure Graphite Stem Packing	14
7.5.2 Bellows Seal Packing	17
7.6 Valve Spare Parts.....	18
7.6.1 Stem ½ Inch Version.....	18

7.6.2	Stem 1¼ Inch Version	23
8	Pneumatic Actuator	28
8.1	Disassembly of the Actuator	28
8.2	Replacing the Diaphragm	28
8.2.1	Spring Close Actuator (Reverse)	28
8.2.2	Spring Open Actuator (Direct)	29
8.3	Changing one or more springs	30
8.3.1	Spring Close Actuator (Reverse)	30
8.3.2	Spring Open Actuator (Direct)	30
8.4	Reassembly of the Actuator	30
8.5	Spare Parts Pneumatic Actuator	33
9	Electric Actuator	34
9.1	Dissassembly of the Actuator	34
9.2	Lubricate the Actuator	34
9.3	Replacing the Motor.....	34
9.4	Actuator REact 15.....	35
9.4.1	Connection Plans REact 15.....	35
9.4.2	Spare Parts REact 15	36
9.5	Actuator REact 30.....	37
9.5.1	Connection Plans REact 30.....	37
9.5.2	Spare Parts REact 30	39
9.6	Actuator REact 60/100	42
9.6.1	Connection Plans REact 60/100	42
9.6.2	Spare Parts REact 60/100.....	44
9.7	Actuator ST 5106.....	47
9.7.1	Connection Plans ST 5106.....	47
9.7.2	Spare Parts ST 5106	49
10	Troubleshooting	51
10.1	Valves	51
10.2	Pneumatic Actuators.....	51
10.3	Electric Actuators	51
10.3.1	Mechanical Problem	51
10.3.2	Electrical Problem	51

List of Figures

Figure 1: Valve Data Plate.....	7
Figure 2: Bonnet Gasket Dimensions.....	9
Figure 3: Typical component overview of 2-way (PTFE/Graphite packing) and 3-way (Graphite packing) valve	11
Figure 4: Typical component overview of QCS 1-stage (PTFE/Graphite packing) and 2-stage (Graphite packing) valve.....	12
Figure 5: PTFE/Graphite NPS ½ - 2½ CL 150 & 300 Stem ½” (Spare Part No. CVSHHNAE)	14
Figure 6: PTFE/Graphite NPS 3 - 6 CL 150 & 300 Stem ½” (Spare Part No. CVSHONAE)	15
Figure 7: PTFE/Graphite NPS 1½ - 12 CL 150 & 300 Stem 1¼” (Spare Part No. CVSQLNAE)	15
Figure 8: Pure Graphite NPS ½ - 2½ CL 150 & 300 Stem ½” (Spare Part No. CVSHHNA).....	15
Figure 9: Pure Graphite NPS 3 - 6 CL 150 & 300 Stem ½” (Spare Part No. CVSHONAA).....	15
Figure 10: Pure Graphite NPS 1½ - 12 CL 150 & 300 Stem 1¼” (Spare Part No. CVSQLNAA)	15
Figure 11: PTFE/Graphite NPS ½ - 4 CL 600 & 900 Stem ½” (Spare Part No. CVSHHRBE)	15
Figure 12: PTFE/Graphite NPS 1½ - 4 CL 600 & 900 Stem 1¼” (Spare Part No. CVSQLRBE)	16
Figure 13: Pure Graphite NPS ½ - 4 CL 600 & 900 Stem ½” (Spare Part No. CVSHHRBA).....	16
Figure 14: Pure Graphite NPS 1½ - 4 CL 600 & 900 Stem 1¼” (Spare Part No. CVSQLRBA).....	16
Figure 15: Bellows Seal NPS ½ - 6 CL 150 Stem ½” (Spare Part No. CVSHHLOI)	17
Figure 16: Bellows Seal NPS 3 - 12 CL 150 Stem 1¼” (Spare Part No. CVSQLLOES)	17
Figure 17: Sectional views of stem ½ Inch 2-way valves.....	18
Figure 18: Sectional views of stem ½ Inch 2-way and 3-way valve	19
Figure 19: Sectional views of stem ½ valves with PTFE/Graphite stem packing	20
Figure 20: Sectional views of stem ½ valves with pure graphite stem packing	20
Figure 21: Sectional view of stem ½ valves with bellows seal and safety stem packing	20
Figure 22: Sectional views of stem 1¼ Inch 2-way valves.....	23
Figure 23: Sectional views of stem 1¼ Inch 2-way and 3-way valves	24
Figure 24: Sectional views of stem 1¼ valves with PTFE/Graphite stem packing.....	25
Figure 25: Sectional views of stem 1¼ valves with pure graphite stem packing	25
Figure 26: Sectional view of stem 1¼ valves with bellows seal and safety stem packing	25
Figure 27: Type plate of Pneumatic Actuator	28
Figure 28: Diaphragm Assembly Spring Close (Reverse)	29
Figure 29: Diaphragm Assembly Spring Open (Direct)	29
Figure 30: Position of Diaphragm Assembly	29
Figure 31: Spring position of ST 6115 / ST 6135 / ST 6160	30
Figure 32: Spring position of ST 6175	30
Figure 33: Reverse Acting (Spring Close)	31
Figure 34: Direct Acting (Spring Open)	31
Figure 35: Spare parts Pneumatic Actuators	33

Figure 36: Type plate of Electric Actuator	34
Figure 37: Standard connection diagram REact 15 E	35
Figure 38: Explosion drawing REact 15	36
Figure 39: Standard connection diagram REact 30 E (Single Phase AC)	37
Figure 40: Standard connection diagram REact 30 DC	37
Figure 41: Standard connection plan REact 30 accessories	38
Figure 42: Explosion drawing REact 30 E with pillars	39
Figure 43: Explosion drawing REact 30 DC with yoke	40
Figure 44: Standard connection diagram REact 60/100 E (Single Phase AC)	42
Figure 45: Standard connection diagram REact 60/100 DC	42
Figure 46: Connection plan REact 60/100 accessories	43
Figure 47: Explosion drawing REact 60/100 E/DC with stroke 60 mm	44
Figure 48: Explosion drawing REact 60/100 E with stroke 80 mm	45
Figure 49: Standard connection diagram ST 5106-20/60	47
Figure 50: Standard connection diagram ST 5106-61	47
Figure 51: Standard connection diagram ST 5106 accessories	48
Figure 52: Explosion drawing ST 5106	49

List of Tables

Table 1: Valve stroke as per plug type	10
Table 2: Bonnet gasket dimensions and tightening torque for bonnet nuts	10
Table 3: Parts Description	13
Table 4: PTFE/Graphite Stem Packing.....	16
Table 5: Graphite Stem Packing.....	16
Table 6: Bellows Seal Stem Packing	17
Table 7: Spare part list stem ½ Inch valves	21
Table 8: Spare part list stem 1¼ Inch valves	26
Table 9: Tightening Torque of Pneumatic Actuator.....	30
Table 10: Pneumatic Actuator part specifications	32
Table 11: Spare parts list Pneumatic Actuator	33
Table 12: Lubrication of Electric Actuator	34
Table 13: Connection diagram abbreviations REact 15	35
Table 14: Spare part list REact 15	36
Table 15: Connection diagram abbreviations REact 30	38
Table 16: Spare part list REact 30	41
Table 17: Connection diagram abbreviations REact 60/100.....	43
Table 18: Spare parts list REact 60/100	45
Table 19: Connection diagram abbreviations ST 5106	48
Table 20: Spare part list ST 5106	50

1 General Information

Control valves shall only be used for the appropriate design and operation data.

The body material and nominal pressure of the valve is stamped on the valve body. This data must be compatible with the operating data and the medium.

Each valve has a unique serial number, which can be found on the valve data plate in the box S/N. When ordering spare parts always give the valve serial number (see Figure 1).

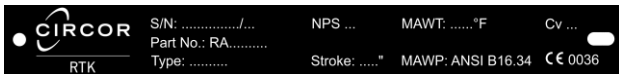



Figure 1: Valve Data Plate

The following Instructions are designed to assist in unpacking, installing and performing maintenance as necessary on REFlex control valves.

Product users and maintenance personnel should thoroughly review these instructions prior to installing, operating or performing any maintenance on the valve.

Installation and maintenance should only be performed by trained and qualified specialist staff

To avoid possible injury to personnel or damage to valve parts, WARNING and CAUTION notes must be strictly followed. Modifying this product, substituting non-factory parts or using maintenance procedures other than outlined could drastically affect performance and be hazardous to personnel and equipment and may void existing warranties.

 **WARNING:** Standard industry safety practices must be adhered to when working on this or any other process control product. Specifically, personal protective and lifting devices must be used as warranted.

2 Safety Terms

The safety terms **DANGER**, **WARNING**, **CAUTION** and **NOTE** are used in these instructions to highlight particular dangers and/or to provide additional information on aspects that may not be readily apparent.

 **DANGER:** Indicates that death, severe personal injury and/or substantial property damage will occur if proper precautions are not taken.

 **WARNING:** Indicates that death, severe personal injury and/or substantial property damage can occur if proper precautions are not taken.

 **CAUTION:** Indicates that minor personal injury and/or property damage can occur if proper precautions are not taken.

 **NOTE:** Indicates and provides additional technical information, which may not be very obvious even to qualified personnel.

3 Unpacking

1. While unpacking the valve, check the packing list against materials received. Lists describing valve and accessories are in each shipping container.

2. When lifting the valve from shipping container, use the lifting lugs (when attached). Take care to position lifting straps to avoid damage to the tubing and mounted accessories.

 **WARNING:** When lifting a valve using the lifting lugs, be aware that the center of gravity may be above the lifting point. Therefore, support must be given to prevent the actuator from rotating. Failure to do so can cause serious injury to personnel, damage to the valve or nearby equipment.

3. Contact your shipper immediately if there is shipping damage.

4. Should any problem arise, contact your Authorized CIRCOR Representative.

4 Installation

Before installing the valve the following items must be considered.

4.1 Installation Space

Be sure to provide proper overhead clearance to ensure maintenance is possible and that there is enough space to remove the actuator/valve trim if necessary. If the valve is installed outdoors, suitable weather protection is required.

4.2 End Caps

Before installation the end caps must be removed from the flanges.

4.3 Cleaning the line

Before installation the line must be cleared of any dirt, welding beads, scale or any other foreign material. A strainer should be installed before the valve to remove any further foreign material.

4.4 Installation Position

Whenever possible the valve should be installed horizontally with the actuator in an upright (12 O-Clock) position, this allows easier maintenance. Vertical Installation is also acceptable, however in this case the actuator mounting pillars must be over each other to support the actuator weight (12 o'clock & 6 o'clock).

4.5 Flow Direction

For 2-way valves flow direction is indicated by the arrow attached to the valve body. For 3-way mixing valves the outlet is marked with A/B and for diverting valves the inlet is marked with A/B.

4.6 Tension on Valve Body

Suitable precautions to prevent any stress or tension on the valve body must be taken.

4.7 Welding the Valve In-line

If welding the valve in line, extreme care must be used to avoid excessive heat build-up in the valve.

4.8 Piping Arrangement

For correct operation of the valve the following minimum pipe distances must be observed and the piping must be straight and free of obstructions.

Inlet > 5 x pipe diameter

Outlet > 10 x pipe diameter

4.9 Actuator Mounting

Valves are normally delivered with the actuator already mounted. In case of removing or replacing the actuator please refer to section **Fehler! Verweisquelle konnte nicht gefunden werden.**

 **CAUTION** For valves with bellows seal the valve stem must not be twisted, this can damage the bellows seal.

If the actuator is removed, the valve stem can be pushed up due to the medium pressure inside the valve

4.10 Electrical Connection

The electrical connection of the actuator must be performed in accordance to the installation and operating instructions of the actuator.

 **WARNING** Always adhere to all relevant safety instructions when working on electrical connections.

Before connecting check that line current, voltage and frequency correspond to the ones given on the actuator data plate.

4.11 Pneumatic Connection

Each valve should be provided with a separate air pressure regulator to avoid interference from an external source.

 **CAUTION** Always use clean, dry instrument air, avoiding moisture, oil or dust. In particular positioners require clean dry instrument air. Please refer to the appropriate actuator and/or positioner data sheet for connections, maximum air supplies and maintenance instructions.

5 Commissioning

All valves are already configured and have undergone a function test in the factory. Therefore adjustment of the actuator is not necessary.

Prior to start up check the control valve by following these steps:

1. Stroke the valve and check the plug position against the stroke scale on the pillar (Refer to Table 1). The plug should change position in a smooth and linear fashion.

NOTE: Due to excessive friction, pure graphite packing can cause the plug stem to move in an erratic fashion.

2. Check for full stroke by making appropriate instrument (pneumatic) or valve positioner (electric) signal changes.

3. Check all air connections for leaks (pneumatic).

4. For valves with pure graphite packing, the packing can be retightened.

CAUTION Do not over tighten the packing. This can cause excessive packing wear and high stem friction that may impede plug movement.

5. For valves with fail safe pneumatic actuators make sure the valve fails in the correct direction in case of loss of air pressure. This is done by turning off the air supply and observing the failure direction.

6. At a suitable moment after start up the bonnet flange bolting can be re-torqued to ensure bonnet gaskets do not leak (Refer to Table 2).

WARNING The bonnet flange bolting must not be re-torqued or loosened while the valve is under pressure, even if a leak occurs.

6 Valve Maintenance

At least once every six months, check the valve for proper operation by following the preventative maintenance steps outlined below. These steps can be performed while the valve is in-line and in **some** cases without interrupting service. If an internal problem is suspected refer to section 7 Valve Disassembly and Reassembly.

1. Look for signs of gasket leakage at the end flanges and bonnet. Re-torque flange and bonnet bolting if required.

2. Examine the valve for damage caused by atmospheric corrosion or process medium dripping.

3. Clean valve and repaint any areas if required.

4. Check packing nut or bolting for proper tightness.

5. If possible, stroke the valve and check for smooth, full-stroke operation (Refer to Table 1). Unsteady stem movement or full stroke not reached could indicate an internal valve problem.

NOTE: Due to excessive friction, pure graphite packing can cause the plug stem to move in an erratic fashion.

WARNING Keep hands, hair and clothing away from all moving parts when operating the valve. Failure to do so can cause serious injury.

6. Ensure all accessories, brackets and bolting are securely fastened.

7. If possible remove air supply and observe actuator for correct fail safe action.

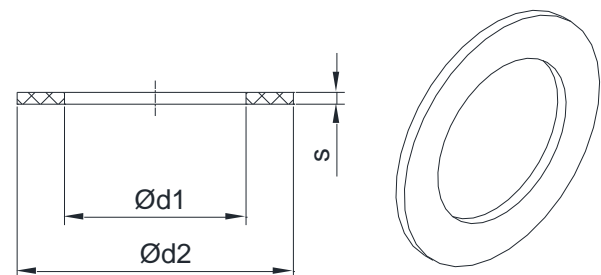

Figure 2: Bonnet Gasket Dimensions

Table 1: Valve stroke as per plug type

	Plug Type	Seat (Inch)																
		¼	¼	¾	½	¾	1	1¼	1½	2	2½	3	4	5	6	8	10	12
Stroke (Inch)	Parabolic	1	1	1	1	1	1	1¼	1¼	1¼	1¼	1¼	1¾ ¹	2	2¾	3	4	4
	Perforated	-	-	1	1	1	1	1¼	1¼	1¼	1½	2	2	2¾	3	4	4	4
	On/off V-port Mixing	½	½	½	½	½	½	½	½	½	½	1	1¼	1¾	1½	2¾	3	4
	Diverting	-	-	-	-	-	½	½	½	½	½	½	1	1¼	1¾	1½	2¾	3

Table 2: Bonnet gasket dimensions and tightening torque for bonnet nuts

Valve Size NPS (DN)	Pressure Class CL (PN)	No. of Holes	Thread mm	Gasket Dimensions Inch (mm)			Tightening Torque ft/lbs (Nm)
				d1	d2	s	
½ (15)	150/300 (16-40)	4	M 10	1.57 (40)	2.13 (54)	0.06 (1.5)	26 (35)
½ (15)	600 (63-160)	4	M 16	1.89 (48)	2.56 (65)	0.06 (1.5)	108 (147)
¾ (20)	150/300 (16-40)	4	M 10	1.57 (40)	2.13 (54)	0.06 (1.5)	26 (35)
¾ (20)	600 (63-160)	4	M 16	1.89 (48)	2.56 (65)	0.06 (1.5)	108 (147)
1 (25+32)	150/300 (16-40)	4	M 12	2.13 (54)	2.68 (68)	0.06 (1.5)	45 (61)
1 (25)	600/900 (63-160)	4	M 20	2.16 (55)	2.95 (75)	0.06 (1.5)	210 (285)
1½ (40)	150/300 (16-40)	4	M 16	2.68 (68)	3.23 (82)	0.06 (1.5)	108 (147)
1½ (40)	600/900 (63-160)	4	M 24	3.0 (76)	3.93 (100)	0.06 (1.5)	361 (490)
2 (50)	150/300 (16-40)	4	M 16	2.68 (68)	3.23 (82)	0.06 (1.5)	108 (147)
2 (50)	600/900 (63-160)	4	M 24	3.54 (90)	4.53 (115)	0.08 (2.0)	361 (490)
2 ½ (65)	150/300 (16-40)	4	M 16	3.66 (93)	4.45 (113)	0.06 (1.5)	108 (147)
2 ½ (65)	600/900 (63-160)	4	M 24	4.33 (110)	5.31 (135)	0.08 (2.0)	361 (490)
3 (80)	150/300 (16-40)	8	M 16	4.33 (110)	5.12 (130)	0.06 (1.5)	108 (147)
3 (80)	600/900 (63-160)	8	M 24	4.53 (115)	5.7 (145)	0.08 (2.0)	361 (490)
4 (100)	150/300 (16-40)	8	M 16	5.31 (135)	6.3 (160)	0.06 (1.5)	108 (147)
4 (100)	600/900 (63-160)	8	M 27	5.31 (135)	6.5 (165)	0.08 (2.0)	535 (725)
(125)	(16-40)	8	M 20	6.3 (160)	7.48 (190)	0.08 (2.0)	210 (285)
(125)	(63-160)	8	M 30	6.5 (165)	8.07 (205)	0.08 (2.0)	726 (985)
6 (150)	150/300 (16-40)	8	M 20	7.48 (190)	8.66 (220)	0.08 (2.0)	210 (285)
6 (150)	600/900 (63-160)	8	M 30	7.87 (200)	9.45 (240)	0.08 (2.0)	726 (985)
8 (200)	150/300 (16-40)	12	M 20	9.45 (240)	10.63 (270)	0.08 (2.0)	210 (285)
8 (200)	600 (63-160)	12	M 33	9.45 (240)	11,0 (280)	0.08 (2.0)	981 (1330)
10 (250)	150/300 (16-40)	12	M 24	11.41 (290)	12.8 (325)	0.08 (2.0)	361 (490)
10 (250)	600 (63-160)	12	M 36	11,0 (280)	13,39 (340)	0.08 (2.0)	1261 (1710)
12 (300)	150/300 (16-40)	16	M 30	13.39 (340)	14.96 (380)	0.08 (2.0)	726 (985)
12 (300)	600 (63-160)	16	M 33	13.58 (345)	14.96 (380)	0.08 (2.0)	981 (1330)
(400)	(16-40)	16	M 33	17.52 (445)	19.29 (490)	0.08 (2.0)	981 (1330)

¹ Valves with ½" stem diameter

² Valves with 1¼" stem diameter

7 Valve Disassembly and Reassembly

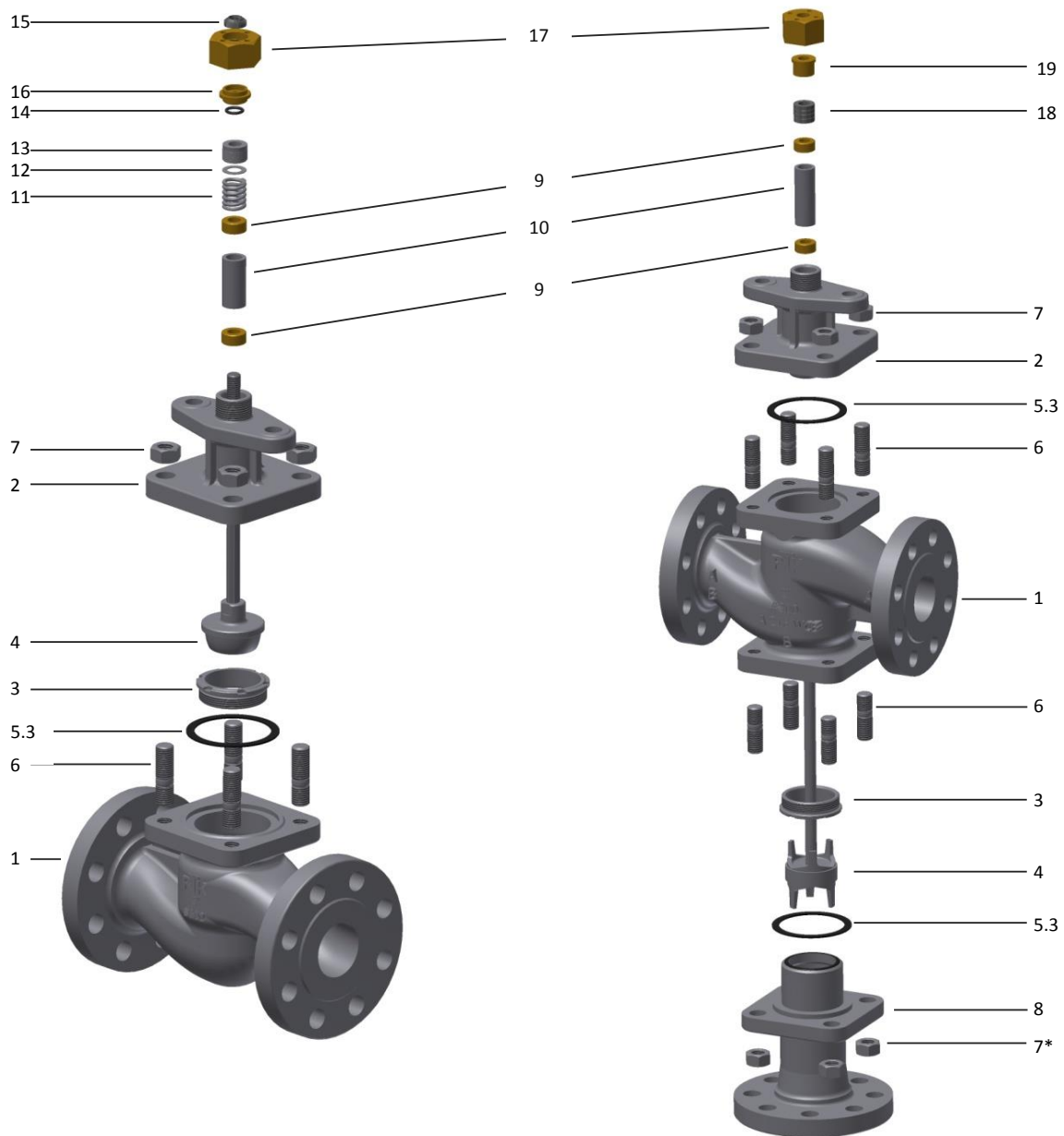

Figure 3: Typical component overview of 2-way (PTFE/Graphite packing) and 3-way (Graphite packing) valve

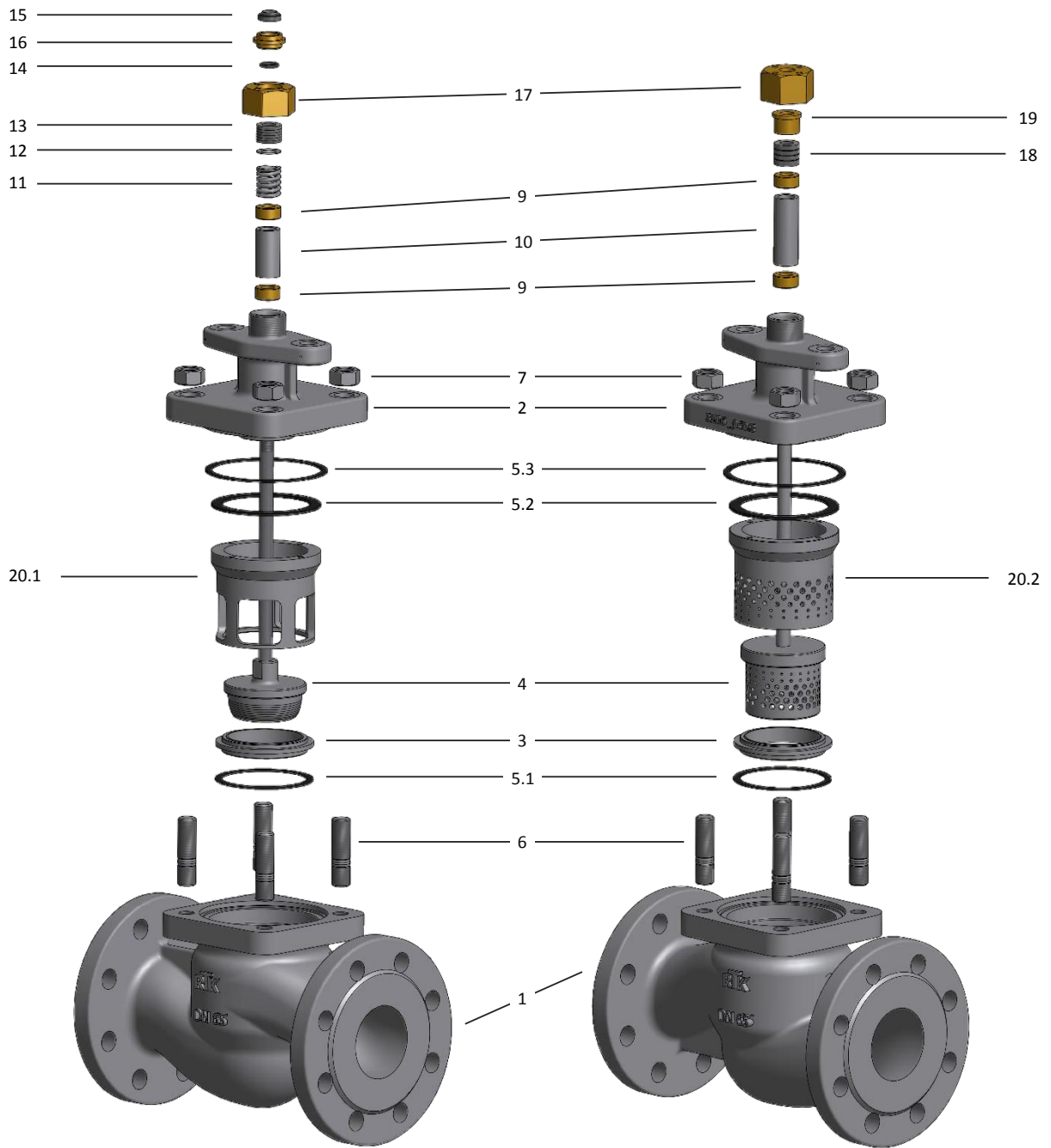

Figure 4: Typical component overview of QCS 1-stage (PTFE/Graphite packing) and 2-stage (Graphite packing) valve

Table 3: Parts Description

Item	Item Description
1	Body
2	Bonnet
3	Seat Ring
4	Plug Assembly
5.1	Seat Ring Gasket (QCS only)
5.2	Retainer Gasket (QCS only)
5.3	Bonnet Gasket
6	Stud
7	Nut
8	B-Flange
9	Guide Bushing
10	Spacer
11	Spring
12	Washer
13	Packing Rings
14	O-Ring
15	Wiper Ring
16	Packing Follower
17	Clamping Nut
18	Packing Rings
19	Packing Follower
20.1	Retainer 1-Stage (QCS)
20.2	Retainer 2-Stage (QCS)

 **WARNING**

- Make sure the relevant pipeline is depressurized and the process medium drained. If necessary allow the control valve to cool down or warm up to ambient temperature prior to starting any work on the valve.
- Follow all required lock out/tag out procedures.
- Make sure the supply air for pneumatic actuators or the power supply for electric actuators and the control signals are disconnected or blocked to prevent any hazards that could be caused by moving parts.
- Special care is needed when the actuator springs are preloaded. These actuators are labeled accordingly.

7.1 Remove the Actuator

For **electric actuators** disconnect the electric power supply and remove the wiring.

For **pneumatic actuators** with **spring to open** relieve the air supply from the actuator and remove the tubing from the upper diaphragm case.

For **spring to close** actuators apply sufficient air to the actuator to move the valve plug away from the valve seat while disengaging the actuator and the valve. After that

relieve the air supply from the actuator and remove the tubing from the lower diaphragm case.

To disengage the actuator and the valve remove the bolts joining the actuator coupling to the valve coupling.

Next, loosen the nuts holding actuator to valve bonnet carefully and remove them. After that lift off the actuator and use lifting assistance if necessary.

7.2 Disassemble the Valve

To disassemble the valve refer to Figure 3, Figure 4, and Table 3 then proceed as follows in the subsections. After all parts have been removed clean them thoroughly with solvent, polish the plug stem with a fine aluminium oxide cloth to remove any foreign particles and/or burrs that may be on the stem. Any worn or damaged parts must be replaced. Be sure all gasket seating areas are clean and smooth.

7.2.1 2-Way Standard Valves

Remove the bonnet nuts (7) and lift the bonnet (2) straight up until it clears the valve plug stem (4). Being careful not to damage the stud (6) threads and stem thread. Take out the plug (4) and remove the bonnet gasket (5.3) (refer to Figure 3, left).

7.2.2 2-Way QCS (Quick Change Seat) Valves

Remove the bonnet nuts (7) and lift the bonnet (2) straight up until it clears the valve plug stem (4). Being careful not to damage the stud (6) threads and stem thread. Take out the plug (4), remove the bonnet and retainer gasket (5.2 and 5.3). Extract the retainer with the help of the 4 holes on top. Take out the seat ring (3) and the seat ring gasket (5.1) (refer to Figure 4, left).

7.2.3 3-Way Mixing Valves

Remove the bonnet (2) and gasket (5.3) as described in section 7.2.1, then remove the B-flange nuts (7*) and remove the B-flange (8). Then carefully take out the plug (4) and remove the bonnet gasket (5.3) (refer to Figure 3, right).

7.2.4 3-Way Diverting Valves

Remove the nuts (7), the bonnet (2), the plug (4) and the gasket (5.3) as described in section 7.2.1. The B-flange (8) can be disassembled as described in section 7.2.3 (refer to Figure 3).

7.3 Replacing the Valve Trim

We recommend also replacing the stem packing when replacing or lapping the seat and/or plug. To replace the stem packing refer to section 7.5.

The plug and seat ring seating surfaces should be free of large scratches or dents, if not they need replacing. Slight damage on the plug seating surface can be eliminated by re-turning the plug on a lathe.

Lift out the valve plug (4). Unscrew the seat ring (3) using an appropriate seat wrench. If needed use appropriate thinner to remove old sealing compound.

Apply sealing compound (Epple 37, Copallite or equivalent) to thread of new seat ring (or the old seat ring when it has been reworked and thoroughly cleaned). Then screw it into the valve body (1) using an appropriate seat wrench and replace the valve plug (4).

7.4 Lapping the Valve Trim

Lapping is the process of mating the valve plug (4) to the seat ring (3) using an abrasive compound. The plug and seat ring sealing surfaces should be free of large scratches or dents, if not, they need replacing.

Use a small amount of good quality lapping compound 500 grit (corn size 2 or 3), apply evenly around the valve plug seating surface.

Carefully insert plug into seat. Install the bonnet onto the valve body and slide the guide bushing (Item 9 of section 7.5) over the valve stem to act as a guide while lapping the seat. Hand tighten two nuts to prevent the bonnet from moving during lapping.

Lap the valve, by applying a slight pressure on the plug stem or relying on the weight of the plug only. Rotate the plug in short oscillating strokes ($\frac{1}{4}$ turn increments). Intermittently lift and rotate the plug 90° to ensure even distribution of the lapping compound and to keep the plug and seat ring concentric.

Clean the seat ring and plug thoroughly when lapping is complete and removing all traces of lapping compound.

Plug and seat ring contact may be checked by the bluing method prior to reassembly.

NOTE: Ensure that the valve plug is not turned against the seat ring (unless lapping) to avoid galling.

7.5 Replacing the Packing

7.5.1 PTFE/Graphite and Pure Graphite Stem Packing

Disassemble the valve as directed in section 7.1 and 7.2.

Remove Clamping Nut (17) then push out the stem packing components (guide bushing (9), spacer (10), spring (11), washer (12), packing rings (13), O-ring (14), wiper ring (9) and packing follower (23)) from the underside of the bonnet (Item 2 of Figure 3). Keep the spacer (10) in a safe place, this must be re-used **It is not part of the replacement packing set.**

Clean inside of the bonnet and the stem as described in section 7.2. Then insert the plug into the seat and install the bonnet onto the valve body using a new bonnet gasket (Item 5 of Figure 3).

Carefully insert each piece of the new packing set in the exact order shown in the accompanying drawing. Remember to re-use the original spacer, unless this is damaged in which case it must be replaced.

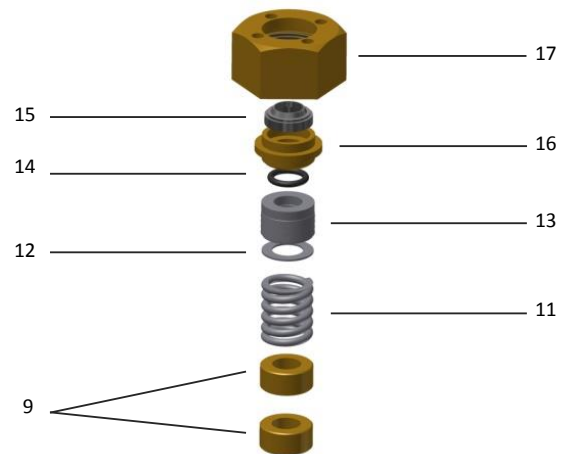

Figure 5: PTFE/Graphite NPS $\frac{1}{2}$ - 2 $\frac{1}{2}$ CL 150 & 300 Stem $\frac{1}{2}$ " (Spare Part No. CVSHHNAE)

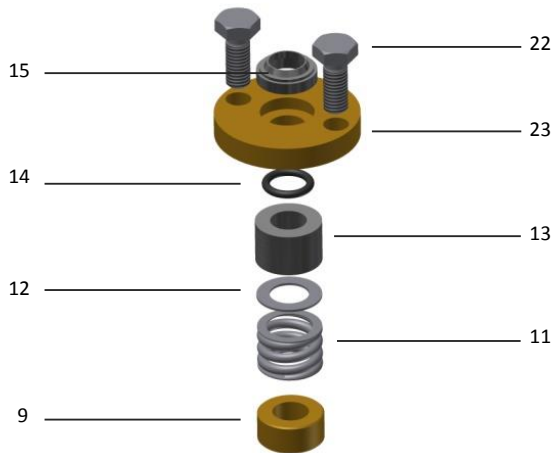

Figure 6: PTFE/Graphite NPS 3 - 6 CL 150 & 300 Stem 1/2"
 (Spare Part No. CVSHONAE)

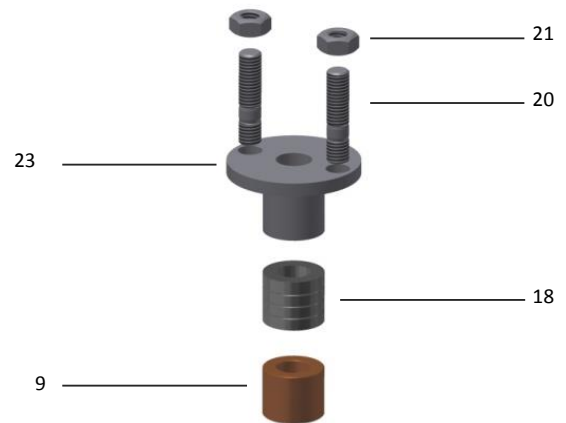

Figure 9: Pure Graphite NPS 3 - 6 CL 150 & 300 Stem 1/2"
 (Spare Part No. CVSHONAA)

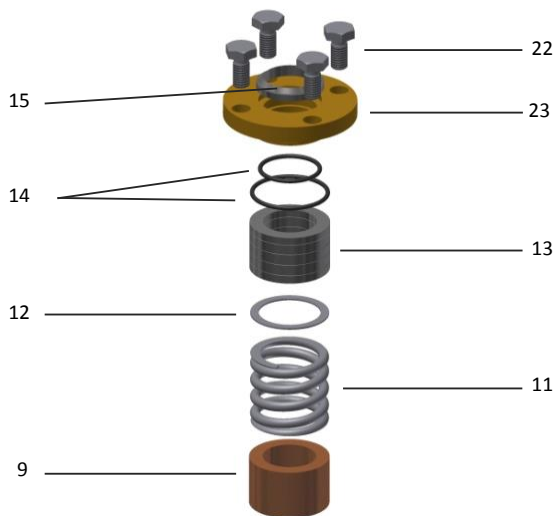

Figure 7: PTFE/Graphite NPS 1 1/2 - 12 CL 150 & 300 Stem 1 1/4"
 (Spare Part No. CVSQLNAE)

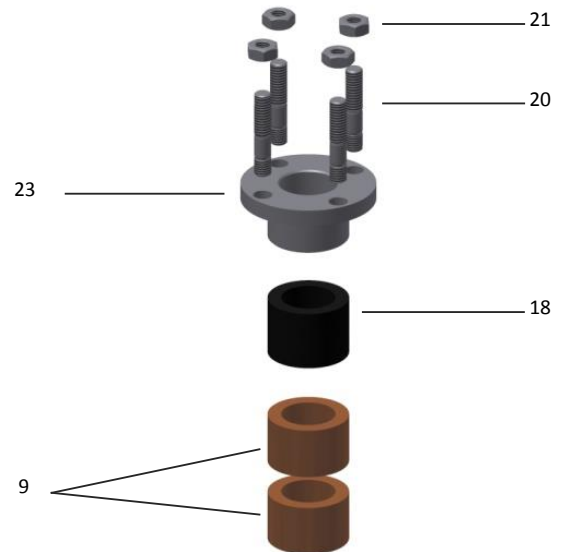

Figure 10: Pure Graphite NPS 1 1/2 - 12 CL 150 & 300 Stem 1 1/4"
 (Spare Part No. CVSQLNAA)

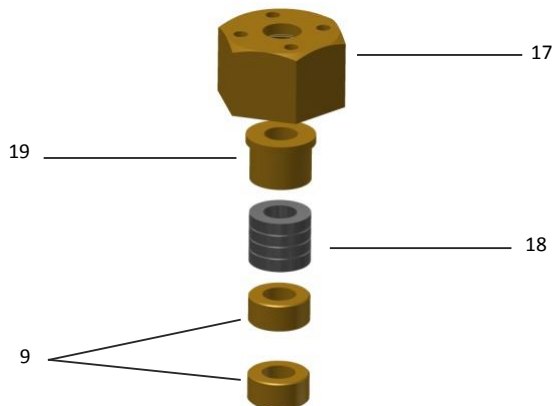

Figure 8: Pure Graphite NPS 1/2 - 2 1/2 CL 150 & 300 Stem 1/2"
 (Spare Part No. CVSHHNAE)

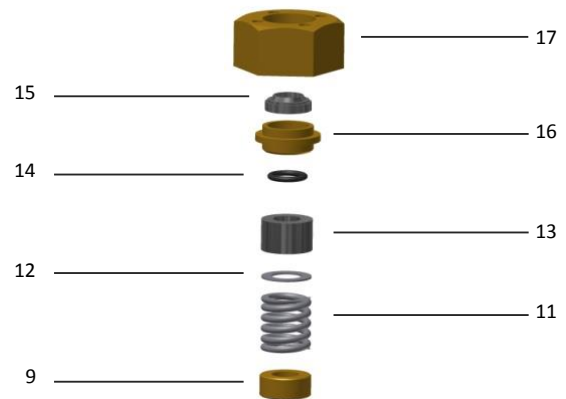

Figure 11: PTFE/Graphite NPS 1/2 - 4 CL 600 & 900 Stem 1/2"
 (Spare Part No. CVSHHRBE)

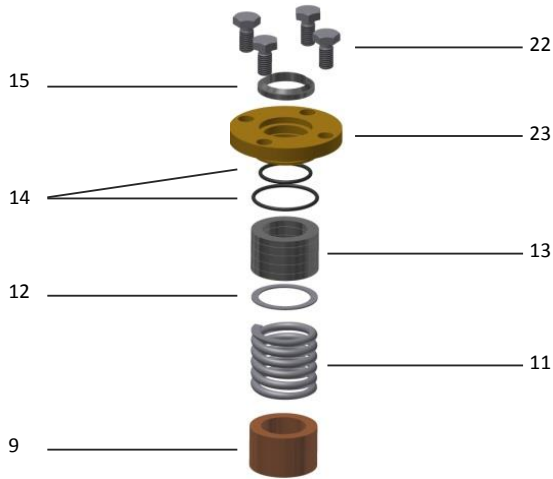

Figure 12: PTFE/Graphite NPS 1 1/2 - 4 CL 600 & 900 Stem 1 1/4" (Spare Part No. CVSQRBE)

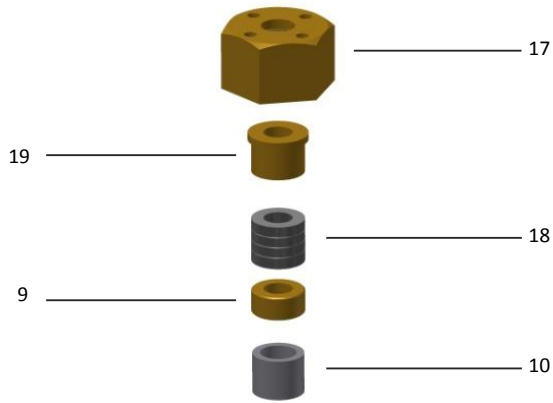

Figure 13: Pure Graphite NPS 1/2 - 4 CL 600 & 900 Stem 1/2" (Spare Part No. CVSHRBA)

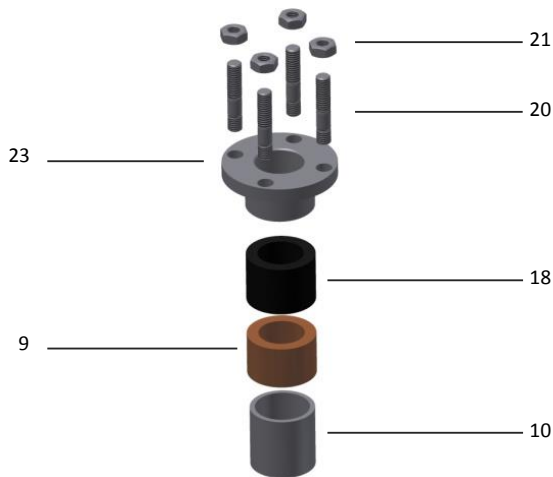

Figure 14: Pure Graphite NPS 1 1/2 - 4 CL 600 & 900 Stem 1 1/4" (Spare Part No. CVSQRBA)

Table 4: PTFE/Graphite Stem Packing

Item	Item Description
17	Clamping Nut
15	Wiper Ring
16	Packing Follower
14	O-Ring
13	Packing (Chevron Rings)
12	Washer
11	Spring
9	Guide Bushing
22	Bolts
23	Mounting Plate

Table 5: Graphite Stem Packing

Item	Item Description
17	Clamping Nut
19	Packing Follower
18	Packing
9	Guide Bushing
21	Nuts
20	Studs
23	Mounting Plate
10	Spacer

7.5.2 Bellows Seal Packing

For NPS ½ to 6 (Figure 15) remove the safety stuffing box by loosening the screw (33), the set screw (31) and the clamp nut (29) in a whole. Then disassemble the valve as directed in section 7.2 carefully.

Insert the new plug with new bellows seal into the valve and install the bonnet onto the valve body by using new bonnet gaskets (Item 34 and 5 of Figure 3). Insert set screw (31) to prevent the bellows seal from twisting then tighten screw (33) Lastly, assemble the new safety stuffing box, which contains the items 24 to 30.

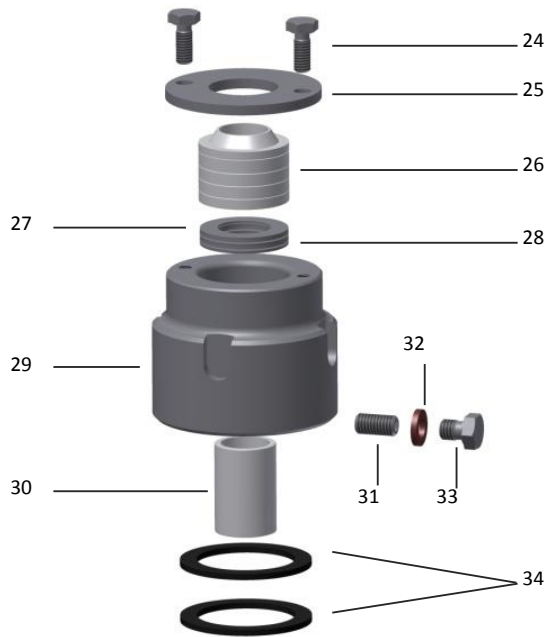

Figure 15: Bellows Seal NPS ½ - 6 CL 150 Stem ½" (Spare Part No. CVSHHLOI)

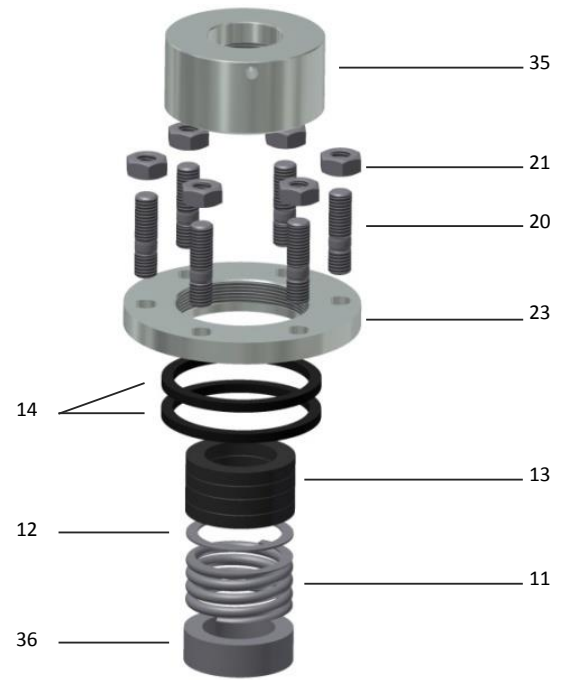

Figure 16: Bellows Seal NPS 3 - 12 CL 150 Stem 1¼" (Spare Part No. CVSQLOES)

Table 6: Bellows Seal Stem Packing

Item	Item Description
24	Bolts
25	Mounting Plate
26	Packing
27	Washer
28	Spring Washer
29	Clamping Nut
30	Guide Bushing
31	Set Screw
32	Seal Ring
33	Screw
34	Gasket
35	Clamping Nut
21	Nuts
20	Studs
23	Mounting Plate
14	Washer
13	Packing
12	Washer
11	Spring
36	Guide Bushing

7.6 Valve Spare Parts

7.6.1 Stem 1/2 Inch Version

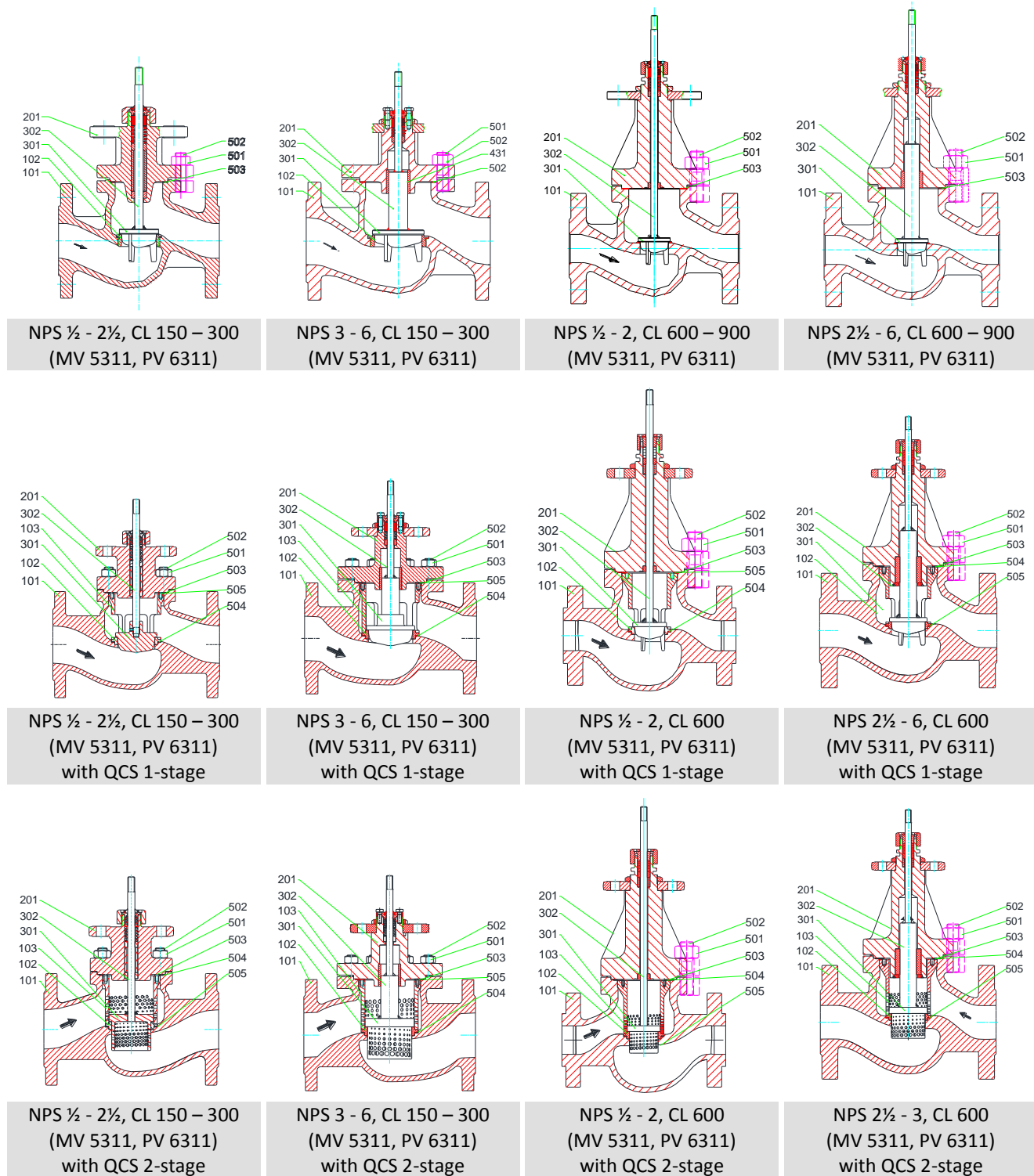
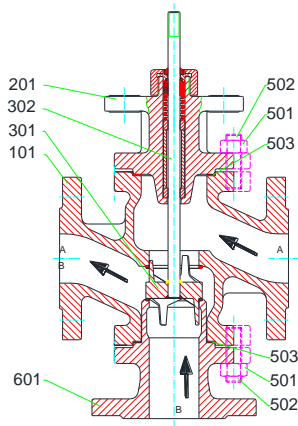
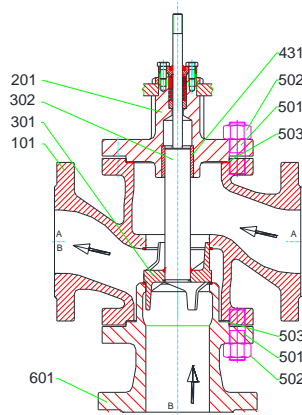

Figure 17: Sectional views of stem 1/2 Inch 2-way valves



NPS 1 - 3, CL 150 – 300
(MV 5321, PV 6321)



NPS 4 - 6, CL 150 – 300
(MV 5321, PV 6321)

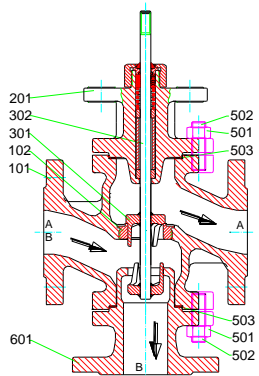

NPS 1 - 3, CL 150 – 300
(MV 5331, PV 6331)

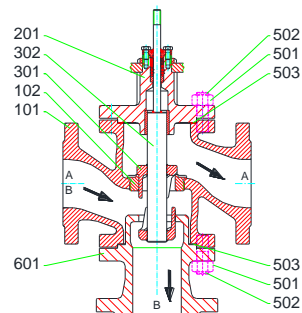

NPS 4 - 6, CL 150 – 300
(MV 5331, PV 6331)

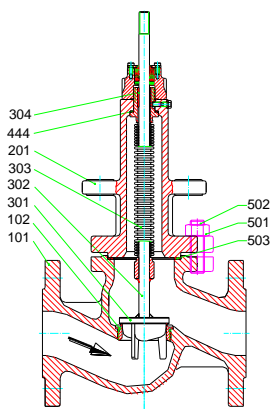

NPS ½ - 6, CL 150
(MV 5314, PV 6314)

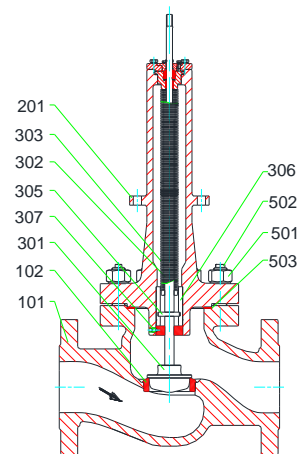

NPS 1½ - 6, CL 600
(MV 5314, PV 6314)

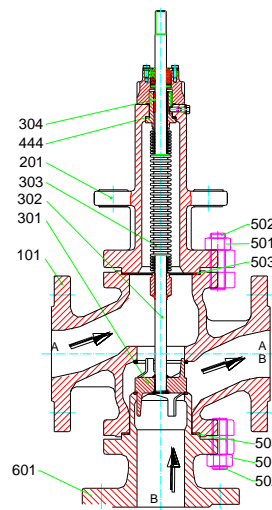

NPS 1 - 6, CL 150
(MV 5324, PV 6324)

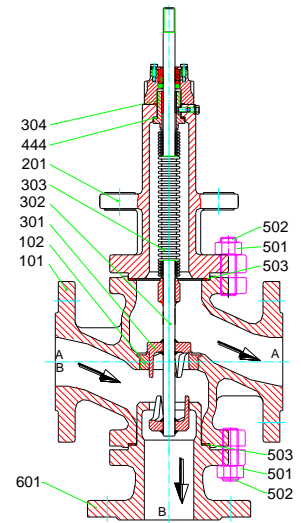

NPS 1 - 6, CL 150
(MV 5334, PV 6334)

Figure 18: Sectional views of stem ½ Inch 2-way and 3-way valve

Stem Packing PTFE/Graphite (max. 482°F)

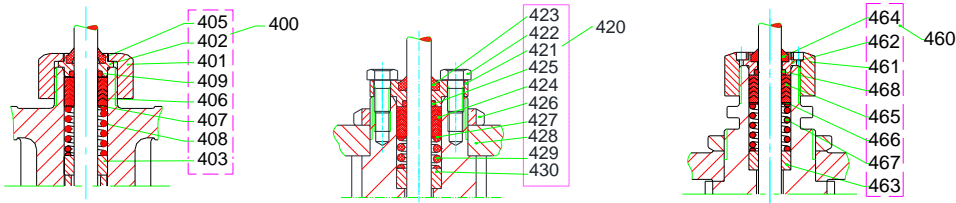

NPS ½ - 2½, CL 150 - 300

NPS 3 - 6, CL 150 - 300

NPS ½ - 6, CL 600 - 900

Figure 19: Sectional views of stem ½ valves with PTFE/Graphite stem packing

Stem Packing Pure Graphite (max. 983)

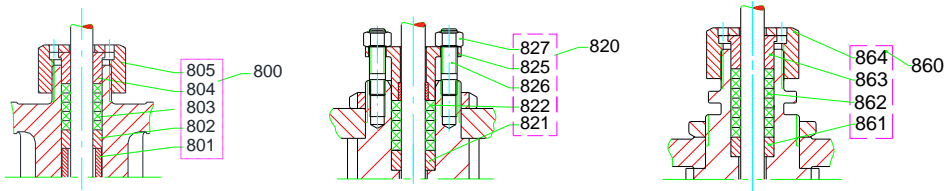

NPS ½ - 2½, CL 150 - 300

NPS 3 - 6, CL 150 - 300

NPS ½ - 6, CL 600 - 900

Figure 20: Sectional views of stem ½ valves with pure graphite stem packing

Safety Packing for Bellows Seal

PTFE (max. 662°F)

Pure Graphite (max. 797°F)

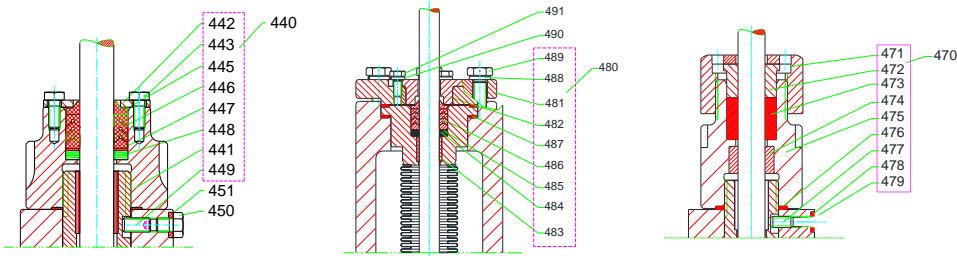

NPS ½ - 6, CL 150

NPS 1½ - 6, CL 600

NPS ½ - 6, CL 150

Figure 21: Sectional view of stem ½ valves with bellows seal and safety stem packing

Table 7: Spare part list stem ½ Inch valves

Item	Description	Material	Part no.
101	body	SA 216 WCB SA 217 WC6 / WC9 SA 351 CF8M	BVG...
102	seat ring	1.4571 (AISI 316Ti)	FSIR...
103	retainer	CA6NM	FHSK...
201	bonnet	SA 216 WCB SA 217 WC6 / WC9 SA 351 CF8M	BVD...
300	plug assembly		BVK....
301	plug head	1.4122	
302	plug stem	1.4571 (AISI 316Ti)	
303	metal bellows	1.4571 (AISI 316Ti)	
304	guide ring	PTFE with 25% glass fiber	
400	stem packing PTFE-graphite		CVSHHNAE
401	cap nut	CuZn39Pb3 (ASTM C38500)	
402	guide bushing	CuSn7Zn4Pb7-C (ASTM C93200)	
403	guide ring	CuSn7Zn4Pb7-C (ASTM C93200)	
405	scraper ring	NBR 90	
406	chevron rings	PTFE/Graphite	
407	washer	1.4301 (AISI 304)	
408	spring	1.4310 (AISI 301)	
409	o-ring	NBR	
420	stem packing PTFE- graphite		CVSHONAE
421	guide bushing	CuSn7Zn4Pb7-C (ASTM C93200)	
422	hex bolt	1.4301 (AISI 304)	
423	scraper ring	NBR 90	
424	chevron rings	PTFE/Graphite	
425	o-ring	EPDM	
427	washer	1.4301 (AISI 304)	
429	spring	1.4310 (AISI 301)	
430	bushing	CuSn7Zn4Pb7-C (ASTM C93200)	
431	bushing	CuSn12-C (ASTM C90800)	
440	bellows seal with stem packing (662°F)		CVSHHLOE
441	cap nut	1.4104 (AISI 430F)	
442	washer	1.4301 (AISI 304)	
443	hex bolt	1.4301 (AISI 304)	
444	gasket	Graphite	
445	scraper ring	PTFE	
446	chevron rings	PTFE	
447	washer	1.4301 (AISI 304)	
448	spring washer set	1.4310 (AISI 301)	
449	grub screw	45H	
450	seal ring	KLINGERSIL® C-4400 L	
451	hex bolt	1.4301 (AISI 304)	
460	stem packing PTFE-graphite		CVSHHRBE
461	cap nut	CuZn39Pb3 (ASTM C38500)	
462	guide bushing	CuSn7Zn4Pb7-C (ASTM C93200)	
463	guide ring	CuSn7Zn4Pb7-C (ASTM C93200)	
465	scraper ring	NBR 90	
466	chevron rings	PTFE/Graphite	

467	washer	1.4301 (AISI 304)	
468	spring	1.4310 (AISI 301)	
469	o-ring	NBR	
470	bellows seal with stem packing (797°F)		CVS...
471	cap nut	1.4104 (AISI 430F)	
472	bushing	1.4571 (AISI 316Ti)	
473	packing	Graphite	
474	bushing	EN-GJS-400-18C-LT	
475	cap nut	1.4104 (AISI 430F)	
476	gasket	Graphite	
477	grub screw	45H	
478	seal ring	KLINGERSIL® C-4400 L	
479	bolt	1.4301 (AISI 304)	
480	bellows seal with stem packing (CL 600)		CVS...
481	flange	1.4571 (AISI 316Ti)	
482	packing follower	1.4571 (AISI 316Ti)	
483	guide ring	PTFE	
484	spring washer set	1.4310 (AISI 301)	
485	chevron rings	PTFE	
486	washer	1.4310 (AISI 301)	
487	gasket	Graphite	
488	spring ring	1.4301 (AISI 304)	
489	nut	1.4301 (AISI 304)	
490	spring ring	1.4301 (AISI 304)	
491	nut	1.4301 (AISI 304)	
501	nut	ASTM A 194 Gr. 2H ASTM A 194 Gr. 8M	DOOP...
502	stud	ASTM A 193 Gr. B7 ASTM A 193 Gr. B8M	DOOQ...
503	bonnet gasket	Graphite	FDIF...
504	retainer gasket	Graphite	FDIF...
505	seat gasket (QCS only)	Graphite	FDIF...
601	B-flange	SA 216 WCB SA 217 WC6 / WC9 SA 351 CF8M	BVB...
800	stem packing graphite		CVSHHNA
801	spacer	1.4301 (AISI 304)	
802	guide bushing	CuSn7Zn4Pb7-C (ASTM C93200)	
803	packing	Graphite	
804	packing follower	CuSn7Zn4Pb7-C (ASTM C93200)	
805	cap nut	CuZn39Pb3 (ASTM C38500)	
820	stem packing graphite		CVSHONAA
821	guide bushing	CuSn7Zn4Pb7-C (ASTM C93200)	
822	packing	Graphite	
825	packing follower	1.4571 (AISI 316Ti)	
826	stud	1.4301 (AISI 304)	
827	nut	1.4301 (AISI 304)	
860	stem packing graphite		CVSHHRBA
861	guide bushing	CuSn7Zn4Pb7-C (ASTM C93200)	
862	packing	Graphite	
863	packing follower	CuSn7Zn4Pb7-C (ASTM C93200)	
864	cap nut	CuZn39Pb3 (ASTM C38500)	

7.6.2 Stem 1¼ Inch Version

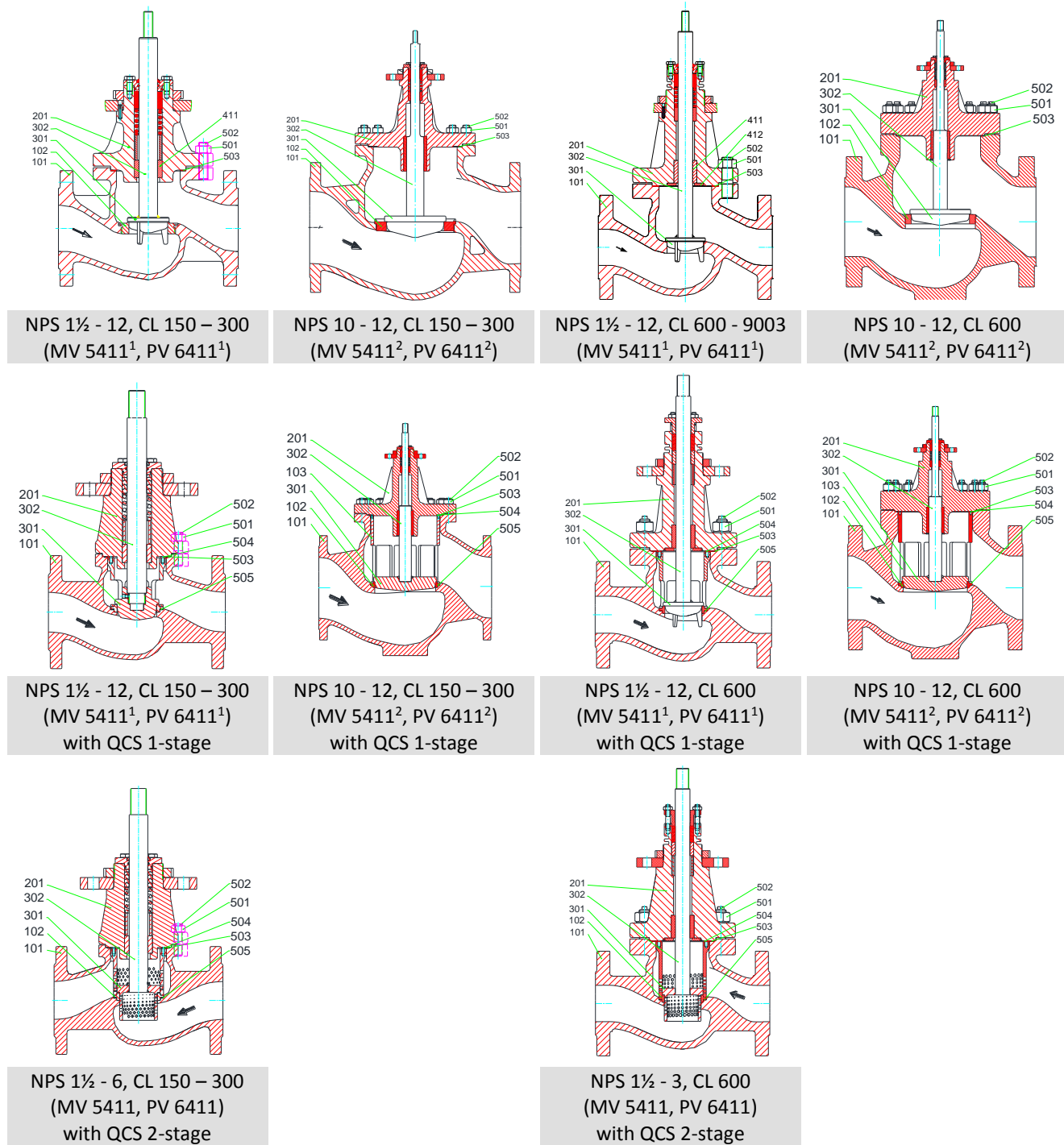
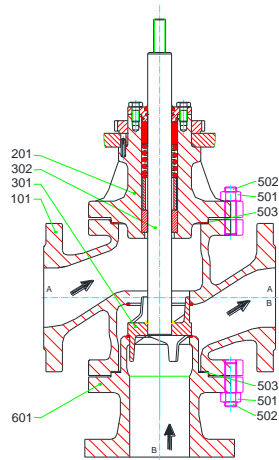
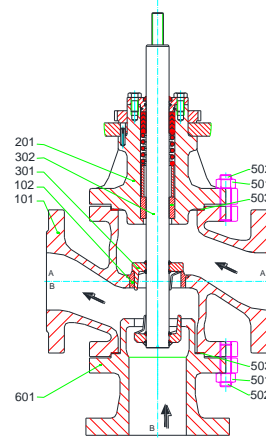

Figure 22: Sectional views of stem 1¼ Inch 2-way valves

- ¹ Up to seat diameter 7 Inch
- ² From seat diameter 8 Inch
- ³ NPS 12 up to CL 600 available



NPS 3 - 12, CL 150 - 300
(MV 5421, PV 6421)



NPS 3 - 12, CL 150 - 300
(MV 5431, PV 6431)

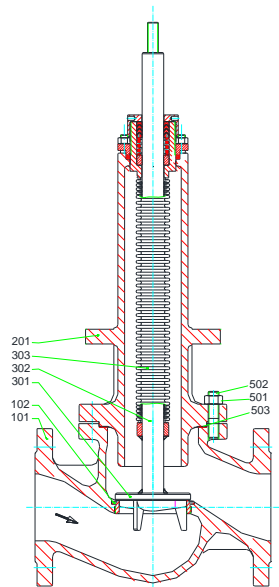

NPS 1½ - 12, CL 150
(MV 5414, PV 6414)

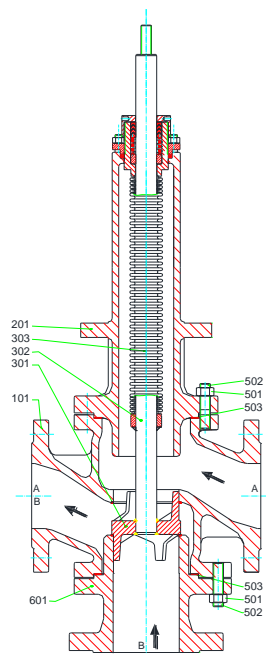

NPS 3 - 12, CL 150
(MV 5424, PV 6424)

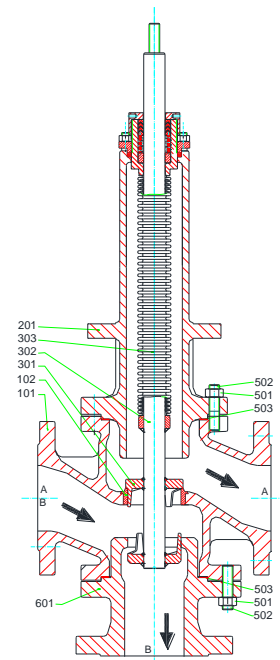

NPS 3 - 12, CL 150
(MV 5434, PV 6434)

Figure 23: Sectional views of stem 1¼ Inch 2-way and 3-way valves

Stem Packing PTFE/Graphite (max. 482°F)

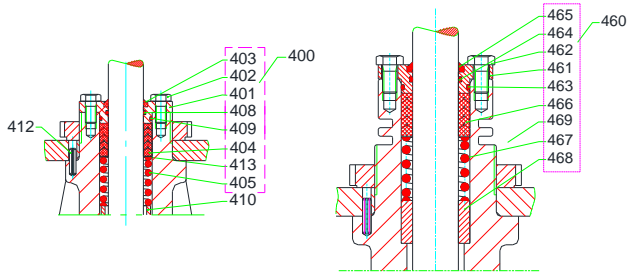

NPS 1½ - 12, CL 150 - 300

NPS 1½ - 12, CL 600 - 900

Figure 24: Sectional views of stem 1/4 valves with PTFE/Graphite stem packing

Stem Packing Pure Graphite (max. 986°F)

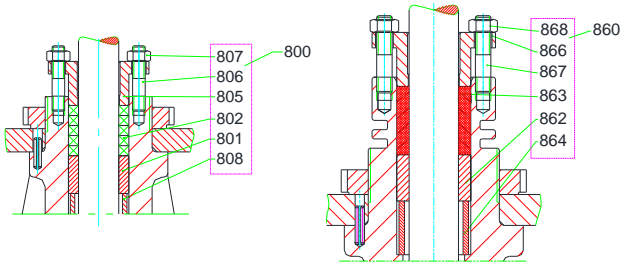

NPS 1½ - 12, CL 150 - 300

NPS 1½ - 12, CL 600 - 900

Figure 25: Sectional views of stem 1/4 valves with pure graphite stem packing

Safety stem packing for bellows seal PTFE (max. 662°F)

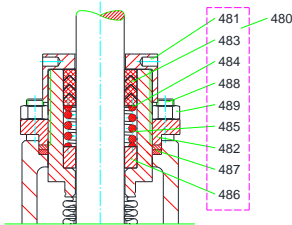

NPS 2½ - 12, CL 150

Figure 26: Sectional view of stem 1/4 valves with bellows seal and safety stem packing

Table 8: Spare part list stem 1¼ Inch valves

Item	Description	Material	Part No.
101	body	SA 216 WCB SA 217 WC6 / WC9 SA 351 CF8M	BVG...
102	seat ring	1.4571 (AISI 316Ti)	FSIR...
103	retainer	CA6NM	FHSK...
201	bonnet	SA 216 WCB SA 217 WC6 / WC9 SA 351 CF8M	BVD...
300	plug assembly		BVK....
301	plug head	1.4122	
302	plug stem	1.4571 (AISI 316Ti)	
303	metal bellows	1.4571 (AISI 316Ti)	
304	guide ring	PTFE with 25% glass fiber	
400	stem packing PTFE-graphite		CVSQLNAE
401	guide bushing	CuSn7Zn4Pb7-C (ASTM C93200)	
402	hex bolt	1.4301 (AISI 304)	
403	scraper ring	NBR 90	
404	chevron rings	PTFE/Graphite	
405	spring	1.4310 (AISI 301)	
408	o-ring	EPDM	
409	o-ring	EPDM	
411	guide ring	CuSn12-C (ASTM C90800)	
413	washer	1.4301 (AISI 304)	
460	stem packing PTFE-graphite		CVSQLRBE
461	guide bushing	CuSn7Zn4Pb7-C (ASTM C93200)	
462	hex bolt	1.4301 (AISI 304)	
463	o-ring	EPDM	
464	o-ring	EPDM	
465	scraper ring	NBR 90	
466	chevron rings	PTFE/Graphite	
467	spring	1.4310 (AISI 301)	
468	guide ring	CuSn12-C (ASTM C90800)	
469	washer	1.4301 (AISI 304)	
480	bellows seal with stem packing (662°F)		CVSQLLOES
481	cap nut	1.4104 (AISI 430F)	
482	packing follower	1.4104 (AISI 430F)	
483	chevron rings	PTFE	
484	washer	1.4301 (AISI 304)	
485	spring	1.4310 (AISI 301)	
486	bushing	PTFE/Graphite	
487	packing	Graphite	
488	stud	1.4301 (AISI 304)	
489	nut	1.4301 (AISI 304)	
501	nut	ASTM A 194 Gr. 2H ASTM A 194 Gr. 8M	D00P...
502	stud	ASTM A 193 Gr. B7 ASTM A 193 Gr. B8M	D00Q...
503	bonnet gasket	Graphite	FDIF...
504	retainer gasket	Graphite	FDIF...
505	seat gasket	Graphite	FDIF...

601	B-flange	SA 216 WCB SA 217 WC6 / WC9 SA 351 CF8M	BVB...
800	stem packing graphite		CVSQLNAA
801	guide ring	CuSn12-C (ASTM C90800)	
802	packing	Graphite	
805	packing follower	1.4571 (AISI 316Ti)	
806	stud	1.4301 (AISI 304)	
807	nut	1.4301 (AISI 304)	
808	spacer	1.4301 (AISI 304)	
860	stem packing graphite		CVSQLRBA
862	guide ring	CuSn12-C (ASTM C90800)	
863	packing	Graphite	
864	Spacer	1.4301 (AISI 304)	
866	packing follower	1.4571 (AISI 316Ti)	
867	stud	1.4301 (AISI 304)	
868	nut	1.4301 (AISI 304)	

8 Pneumatic Actuator

The instruction is suitable for the following actuators:

ST 6115

ST 6135

ST 6160

ST 6175

Each actuator has a unique serial number which can be found on the data plate affixed to the actuator. When ordering spare parts, or replacements always give the actuator serial number.

Pneum. Actuator: ST	
Act. direction	:
Air supply max.	: psi
Diaphragm Area	: Inches ²
Stroke	: Inch
Spring range	: psi
Normspecification	: xxxxxxxxxx
Serial-No.	: xxxxxxxxxx
Code	: Pxxxxxxxxxxxxx



  Regeltechnik Kornwestheim GmbH
Max-Planck-Str. 3; 70806 Kornwestheim, Germany

Figure 27: Type plate of Pneumatic Actuator

8.1 Disassembly of the Actuator

Remove the actuator from the valve as described in section 7.1.

Loosen the set screw (18) on the arrester (17) then loosen the nut (19). Remove the pillars (21). With the use of a locknut (tighten two nuts against each other, then by unscrewing the bottom one the pillar can be removed) (refer to Figure 33 and Figure 34).

Using a vernier caliper measure the distance between the underside of the parallel guide (20) and the end of the actuator stem (16) this distance must be noted for readjustment later. Loosen and remove the nut (19), parallel guide (20) and the arrester (17). Mark the upper (6) and lower casings (11) for reassembly later (refer to Figure 33 and Figure 34).

Remove the regular casing bolts (7) gradually, alternately loosen the nuts on the remaining long casing bolts (7) to allow decompression of actuator springs (refer to Figure 33 and Figure 34).

 **WARNING** As the springs in the actuator are compressed this creates a force between the upper and lower casings, care must be taken when removing the casing bolts.

8.2 Replacing the Diaphragm

8.2.1 Spring Close Actuator (Reverse)

Remove upper casing (6) then remove the springs (10). Take out the diaphragm assembly (consisting of diaphragm (4), actuator stem (16) diaphragm ring (2) and diaphragm plate (3)). Clamp the diaphragm plate in a vice and unscrew the actuator stem (16) with the use of a locknut (refer to Figure 33 and Figure 34).

Remove the old diaphragm and replace with a new one. Place the diaphragm plate (3) on the new diaphragm, then turn the diaphragm over and place the diaphragm ring (2) on the other side, apply Loctite 270 to the thread on the actuator stem (16) then screw this into the diaphragm plate (3) by hand (refer to Figure 28, Figure 33 and Figure 34).

Important, one of the bolting holes of the diaphragm must be in line with one of the spring holders on the diaphragm plate and the center of the diaphragm plate (refer to Figure 30). Then fully tighten the actuator stem.

Unscrew the 3 bolts (12) fastening the connection flange to the lower casing (11). Remove the seal (14) from the connection flange and replace with the new seal (refer to Figure 33 and Figure 34). Place the lower casing over the connection flange (paying attention that the holes line up) Apply Loctite 270 on the thread of the 3 bolts, then tighten them with torque 11.8 ft-lbs (16 Nm).

Place the diaphragm assembly in the lower casing, paying attention that a bolting hole in the diaphragm, a hole in the lower casing, the air connection in the lower casing, the spring holder on the diaphragm plate and the center of the diaphragm plate are in line (Figure 30). Replace the springs, pay attention to the correct spring position (refer to Figure 31 and Figure 32). Then reassemble the actuator as described in section 8.4.



Figure 28: Diaphragm Assembly Spring Close (Reverse)



Figure 29: Diaphragm Assembly Spring Open (Direct)

8.2.2 Spring Open Actuator (Direct)

Remove upper casing (6). Take out the diaphragm assembly (consisting of diaphragm (4), actuator stem (16), diaphragm ring (2) and diaphragm plate (3)), then remove the springs (10). Clamp the diaphragm plate in a vice and unscrew the diaphragm ring bolt (5) clamping the diaphragm between the diaphragm plate and the diaphragm ring (refer to Figure 33 and Figure 34).

Remove the old diaphragm and replace with a new one. Place the diaphragm plate (3) on the new diaphragm, then turn the diaphragm over and place the diaphragm ring on the other side, apply Loctite 270 to the thread on the bolt then screw this into the diaphragm plate by hand (refer to Figure 29, Figure 33 and Figure 34).

Important, one of the bolting holes of the diaphragm must be in line with one of the spring holders on the diaphragm plate and the center of the diaphragm plate. Then fully tighten the bolt (refer to Figure 30).

Unscrew the 3 bolts (12) fastening the connection flange to the lower casing (11). Remove the seal (14) from the connection flange and replace with the new seal. Place the lower casing over the connection flange (paying attention that the holes line up) Apply Loctite 270 on the thread of the 3 bolts, then tighten them with torque 11.8 ft-lbs (16 Nm).

Place the upper casing upside down on a work bench, then place the diaphragm assembly in upper casing paying attention that a hole in the diaphragm, a hole in the upper casing, the air connection in the upper casing, the spring holder on the diaphragm plate and the centre of the diaphragm plate are in line. Replace the springs, pay attention to the correct spring position (refer to Figure 31 and Figure 32).

Then reassemble the actuator as described in section 8.4.

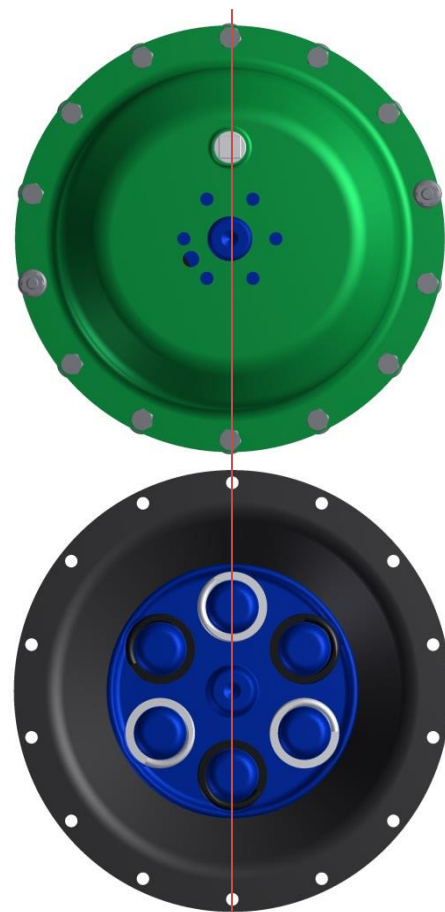

Figure 30: Position of Diaphragm Assembly

8.3 Changing one or more springs

Remove the actuator from the valve as described in section 7.1.

8.3.1 Spring Close Actuator (Reverse)

Remove the upper casing. Change the spring(s), the end of the spring should be facing the outside of the casing. Replace the springs, pay attention to the correct spring position (refer to Figure 31 and Figure 32). Then reassemble the actuator as described in section 8.4.

8.3.2 Spring Open Actuator (Direct)

Remove the upper casing. Take out the diaphragm assembly and remove the old springs. Place the upper casing upside down on a work bench, then place the diaphragm assembly in the upper casing paying attention that a hole in the diaphragm, a hole in the upper casing, the air connection in the upper casing, the spring holder on the diaphragm plate and the center of the diaphragm plate are in line. Replace the springs, pay attention to the correct spring position (refer to Figure 31 and Figure 32). Then reassemble the actuator as described in section 8.4.

8.4 Reassembly of the Actuator

Fit the upper casing (ensure that the air connections in the upper and lower casings are over each other) Also ensure that the marks made on the upper and lower casings (section 8.1) line up. First mount and tighten (alternately) the long casing bolts (don't fully tighten) then mount and tighten the regular casing bolts, finally fully tighten the long casing bolts. The max tightening torque is shown in Table 9 below.

Table 9: Tightening Torque of Pneumatic Actuator

Actuator	Bolt	Torque in ft-lbs (Nm)
ST 6115 ST 6135 ST 6160	M6	8.85 (12)
ST 6175	M8	19.2 (26)

Mount the arrester (17) and nut (19) on the actuator stem (16), then screw the parallel guide onto the actuator stem. Using vernier calipers ensure that the distance between the underside of the parallel guide (20) and the end of the actuator stem (16) is the same as measured in section 8.1. The nose on the parallel guide (20) must be on the same side as the air connectors on the connection flange. Screw in the pillars (21), then tighten the nut and the set screw (18) on the arrester (17). Mount the actuator on the valve as described in section 7.

With spring type G or S

-R H spring ●

-L H spring ◐

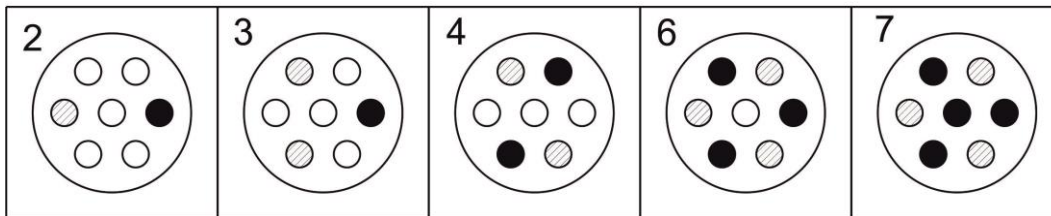

Figure 31: Spring position of ST 6115 / ST 6135 / ST 6160

With spring type S or D

-R H spring ○

-L H spring ⊙

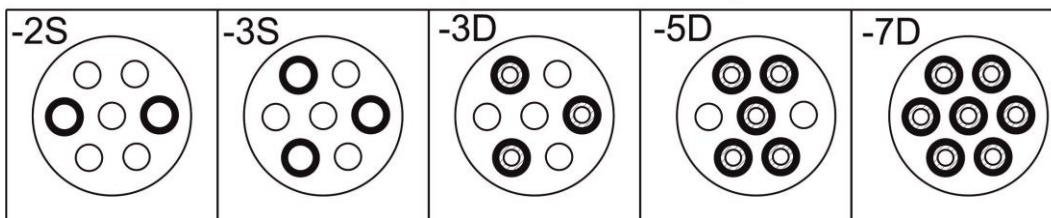

Figure 32: Spring position of ST 6175

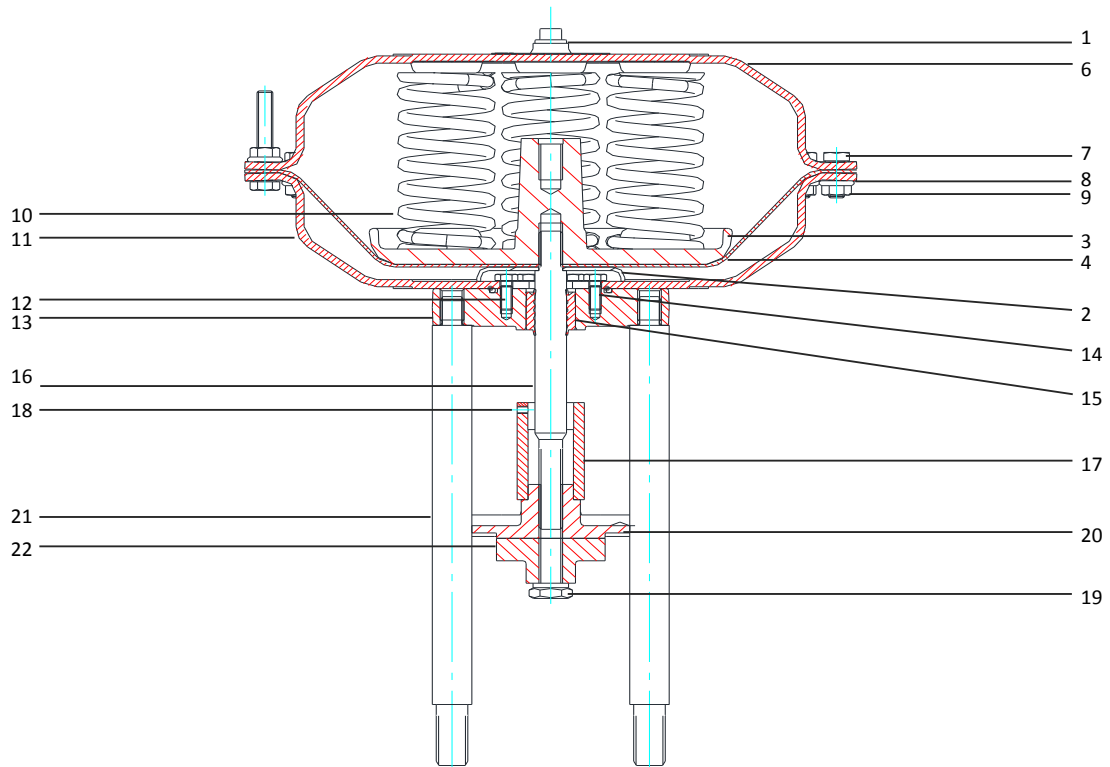

Figure 33: Reverse Acting (Spring Close)

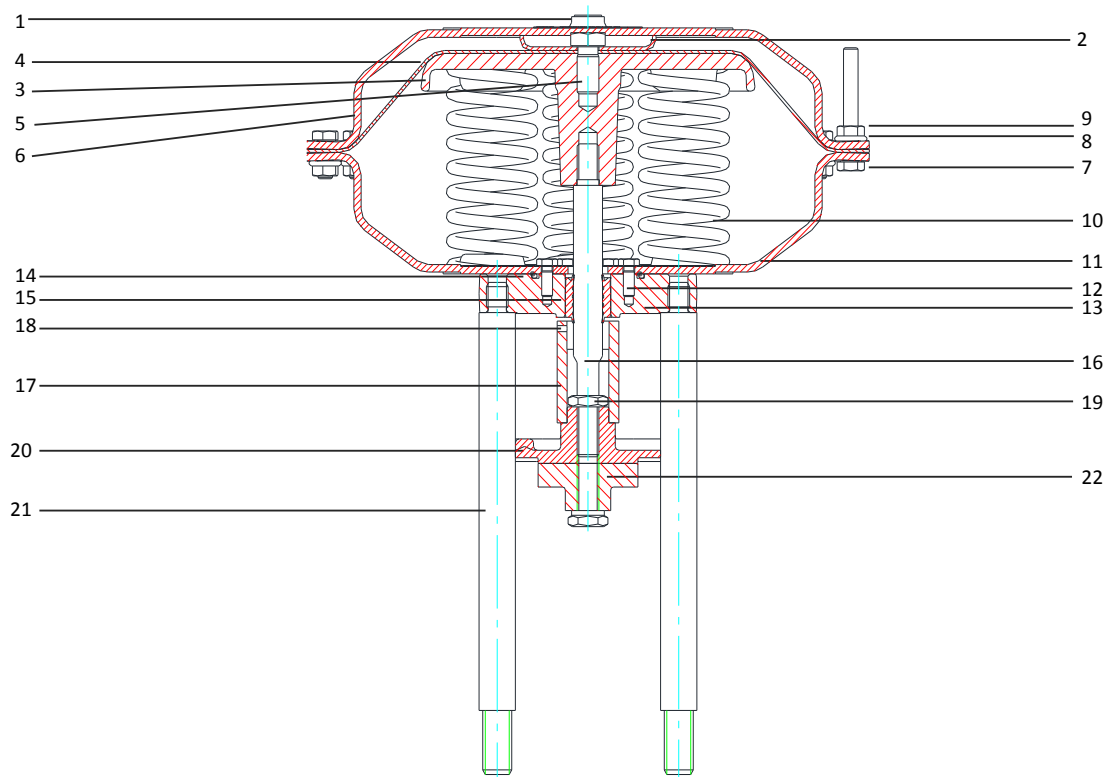

Figure 34: Direct Acting (Spring Open)

Table 10: Pneumatic Actuator part specifications

Item	Item Description	Material	Material Spec	(ANSI Equivalent)
1	Drain Plug	Polypropylene	PP	PP
2	Diaphragm Ring	Steel	1.0114	S235J0
3	Diaphragm Plate	Ductile Iron	JS-1025	A536
4	Diaphragm	Elastomer	EPDM	EPDM
5	Diaphragm Ring Bolt	Stainless Steel	1.4301	AISI 304
6	Upper Casing	Steel	1.0976	A1011
7	Bolt	Steel	8.8	
8	Locking Washer	Steel		
9	Nut	Steel	8.8	
10	Spring Set	Spring Steel	FDSiCr	CrSi Alloy
11	Lower Casing	Steel	1.0976	A1011
12	Connecting Flange Bolts	Stainless Steel	1.4571	AISI 316 Ti
13	Connecting Flange	Steel	1.0619	A216 WCB
14	Connecting Flange Seal	Elastomer	NBR	NBR
15	Actuator Stem Seal	Elastomer	AU	AU
16	Actuator Stem	Stainless Steel	1.4404	AISI 316L
17	Arrester	Steel		
18	Arrester Fixing Set Screw	Steel		
19	Nut	Steel		
20	Parallel Guide	Copper Alloy	CuAl10Fe5Ni5-C	C95800
21	Pillar	Stainless Steel	1.4104	AISI 430F
22	Coupling	Stainless Steel	1.4104	AISI 430F

8.5 Spare Parts Pneumatic Actuator



Figure 35: Spare parts Pneumatic Actuators

Table 11: Spare parts list Pneumatic Actuator¹

Item	Description	Actuator	Material	Material Spec.	(ANSI Equivalent)	Part Number
100	Diaphragm Assembly	ST6115 ST6135 upto 07/2010 ST6135 from 08/2010 ST6160 upto 07/2010 ST6160 from 08/2010	Elastomer	EPDM	EPDM	CMEM15A60009 CMEM35B60009 CMEM35B60019 CMEM60A60009 CMEM60A60019
		ST6175		NBR	NBR	CMEM61750009
10	Spring Set	ST6115.A6-3S ST6115.C6-4S ST6135.B6-2G ST6135.B6-6G ST6160.A6-6G ST6160.C6-3G ST6160.C6-7G ST6175-B6-2S ST6175-B6-3D ST6175-B6-5D ST6175-B6-7D ST6175-C6-2S ST6175-C6-3D ST6175-C6-5D ST6175-C6-7D	Spring Steel	FDSiCr	CrSi Alloy	CFER15A63S09 CFER15C64S09 CFER35B62G09 CFER35B66G09 CFER60A66G09 CFER60C63G09 CFER60C67G09 CFER75B62S09 CFER75B63D09 CFER75B65D09 CFER75B67D09 CFER75C62S09 CFER75C63D09 CFER75C65D09 CFER75C67D09
16	Actuator Stem	ST6115/6135 ST6160.A6 ST6160.C6	Stainless Steel	1.4404	AISI 316 L	CSTK61150009 CSTK6160A609 CSTK6160C609
		ST6175.B6 (spring close) ST6175.B6 (spring open) ST6175.C6 (spring close) ST6175.C6 (spring open)		1.4571	AISI 316 Ti	CSTK6175B609 CSTK6175B619 CSTK6175C009 CSTK6175C019

¹ When ordering spare parts please state actuator type and serial number (see data plate). When ordering motors and capacitors please state power supply.

9 Electric Actuator

The instruction is suitable for the following actuators:

REact 15 E

REact 30 E / DC

REact 60 E / DC

REact 100 E / DC

ST 5106

Each actuator has a unique serial number which can be found on the data plate affixed to the actuator (refer to Figure 36). When ordering spare parts or replacements always give the actuator serial number.

Elect. Actuator: REact	
Actuator Speed	: Inch/min
Force	: lbs/F
Temperature	: -4°F - 158°F
Protection Class	: IP 65
Voltage	: VAC ... Hz
Motor	: rpm
Pwr. Consmt	: VA
Serial-No.	: xxxxxxxxxxxxxx
Code	: Mxxxxxxxxxxxx
 Regeltechnik Kornwestheim GmbH Max-Planck-Str. 3; 70806 Kornwestheim, Germany	

Figure 36: Type plate of Electric Actuator

Table 12: Lubrication of Electric Actuator

Actuator	Part	Lubricant / Manufacturer	Amount	Interval
REact 15	Lubrication not required	-	-	-
REact 30 REact 60	Gear wheel and Bearing (Grease nipple form D 05 K1A)	Divinol Lithogrease '0' / Zeller + Gmelin	6 g	8000 operating hrs
REact 100 ST 5106	Stem and stem nut (Grease nipple form D 05 K1A)	FCH Longterm 2 Plus / Molykote	8 g	4000 operating hrs

9.1 Dissassembly of the Actuator



WARNING Always ensure the actuator is isolated from the electrical supply before beginning any work on the actuator.

Remove the actuator from the valve as described in section 7.1.

Loosen the screw (ST 5106: two screws) fastening the actuator cover to the actuator base, then lift the actuator cover off.

9.2 Lubricate the Actuator

The gearbox and the stem nut thread should be relubricated after a specific interval dependent on the actuator type. The appropriate interval and a suitable lubricant can be found in Table 12.

9.3 Replacing the Motor

Disconnect the motor at terminals M1, M2 and M3. Loosen and remove the 4 bolts fixing the motor to the motor mounting plate. Remove the old motor and replace it with a new one. Replace and retighten the 4 motor mounting bolts. Reconnect the motor at terminals M1, M2 and M3.

9.4 Actuator REact 15

9.4.1 Connection Plans REact 15

Single Phase AC:

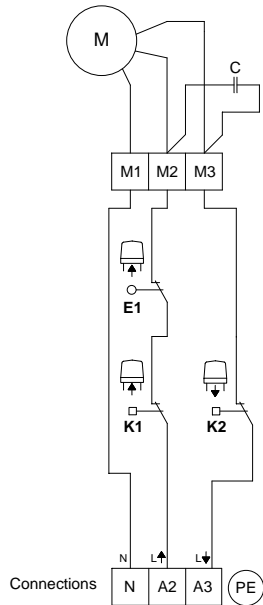

Accessories

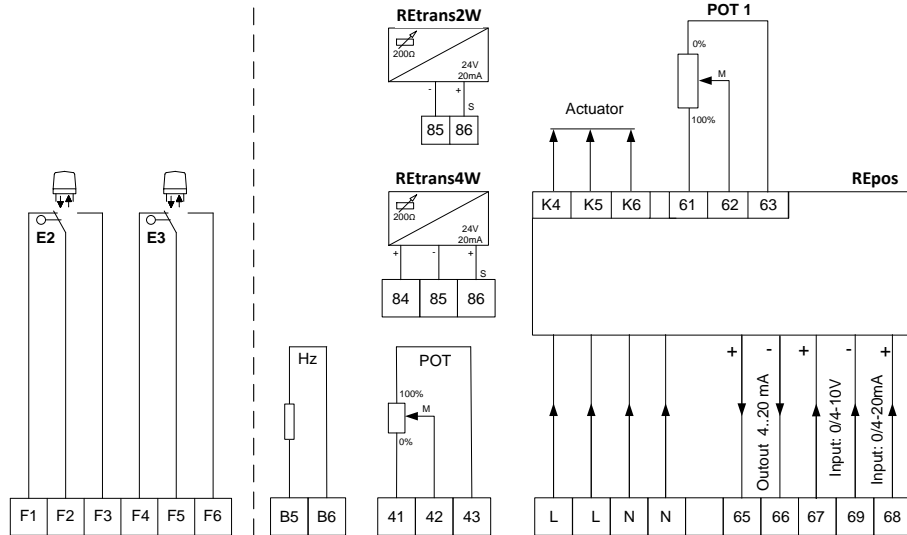

Figure 37: Standard connection diagram REact 15 E

Table 13: Connection diagram abbreviations REact 15

K1	Force switch (open direction)
K2	Force switch (closed direction)
E1	Limit switch (open position)
E2	Limit switch (Intermediate position)
E3	Limit switch (Intermediate position)
Pot	Potentiometer
Hz	Heating element
REtrans	Position transducer
REpos	Digital valve positioner
C	Capacitor

9.4.2 Spare Parts REact 15

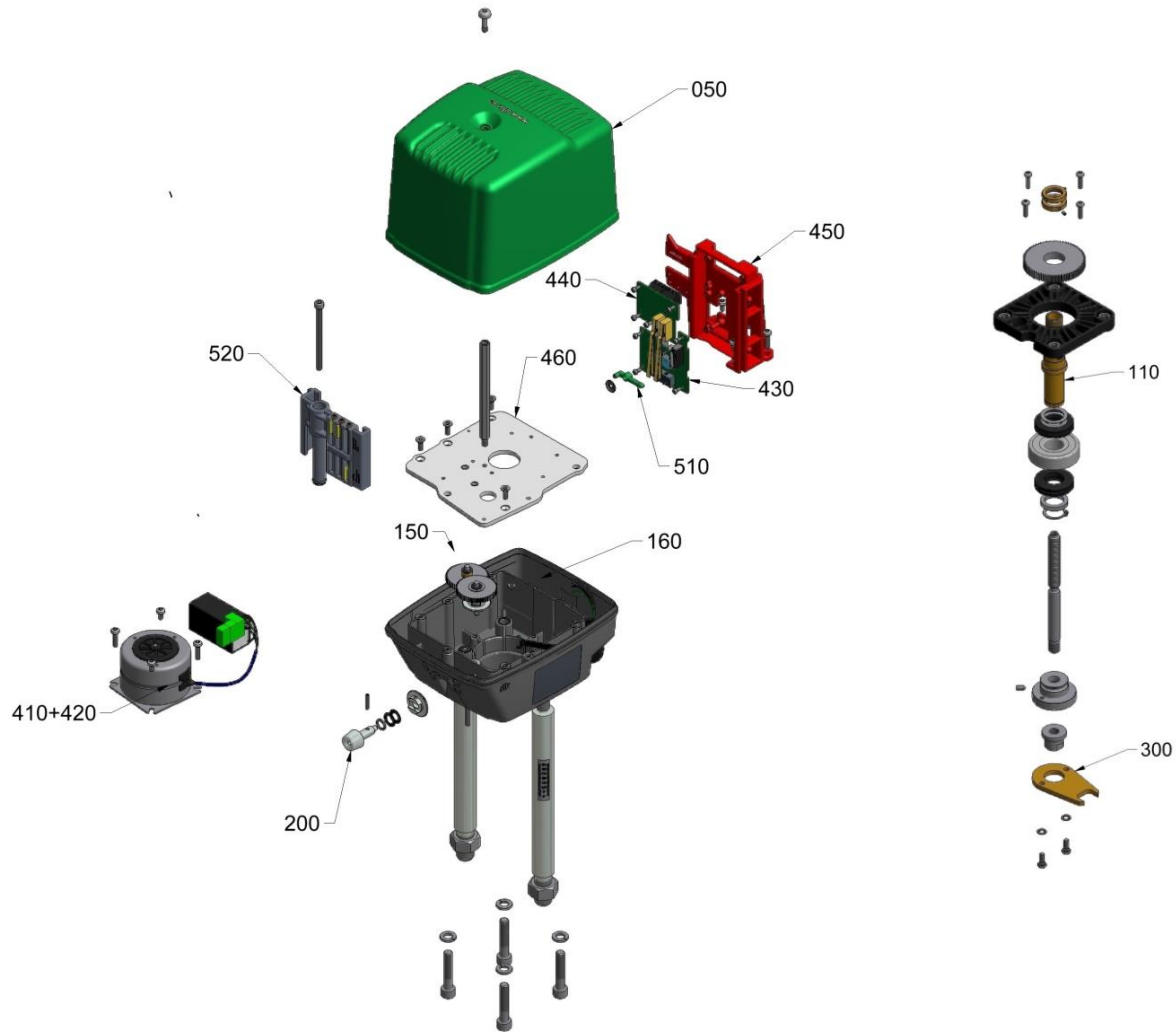

Figure 38: Explosion drawing REact 15

Table 14: Spare part list REact 15¹

Item	Item Description	Part No.
050	cover	CADH15R00009
110	stem nut group	CSPT15R00009
150	gear wheel 2	CZRA15R20009
160	gear wheel 1	CZRA15R10009
200	hand wheel	CRAH15R00009
300	coupling	CKUK51120009
410 + 420	motor + capacitor + motor plug (please state voltage and frequency required)	CMOK15RB...
420	capacitor	GKDS00200009
430	limit switch PCB	CPLE15R00009
440	bracket	CTRA15R00009
450	motor plate	CMOP15RB0009
510	switching clutch	CFEB15R00009
520	cam plate	CFFE15R00009

¹ When ordering spare parts please state actuator type and serial number (see data plate). When ordering motors and capacitors please state power supply.

9.5 Actuator REact 30

9.5.1 Connection Plans REact 30

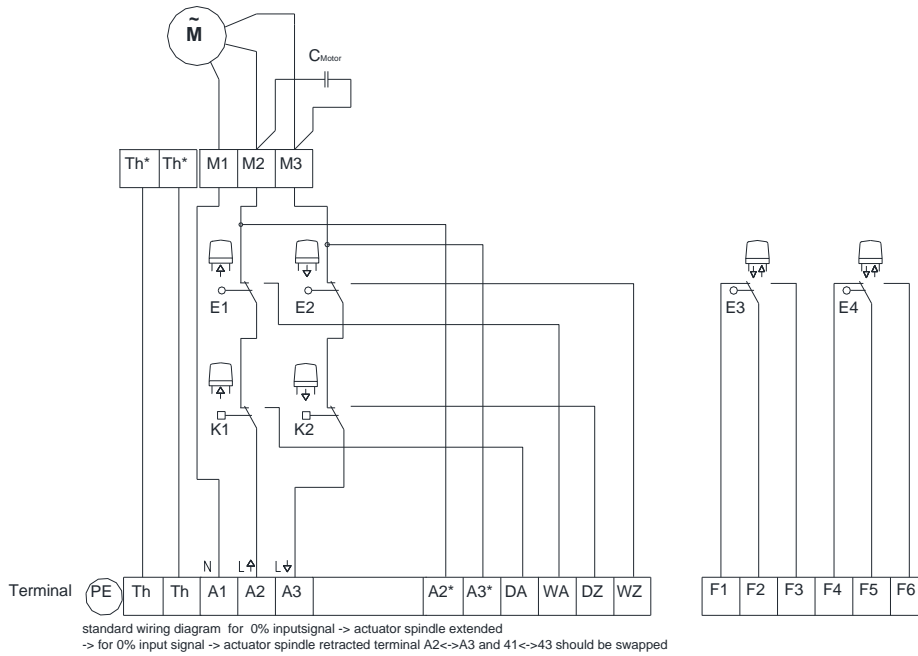

Figure 39: Standard connection diagram REact 30 E (Single Phase AC)

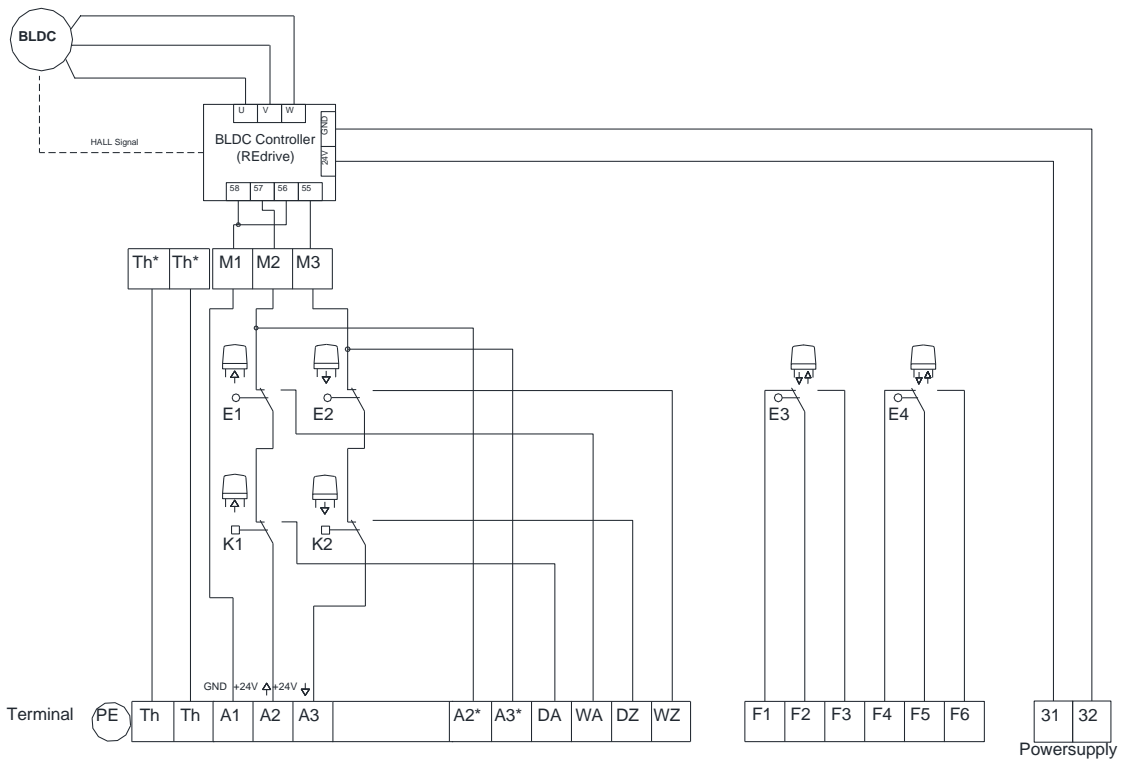

Figure 40: Standard connection diagram REact 30 DC

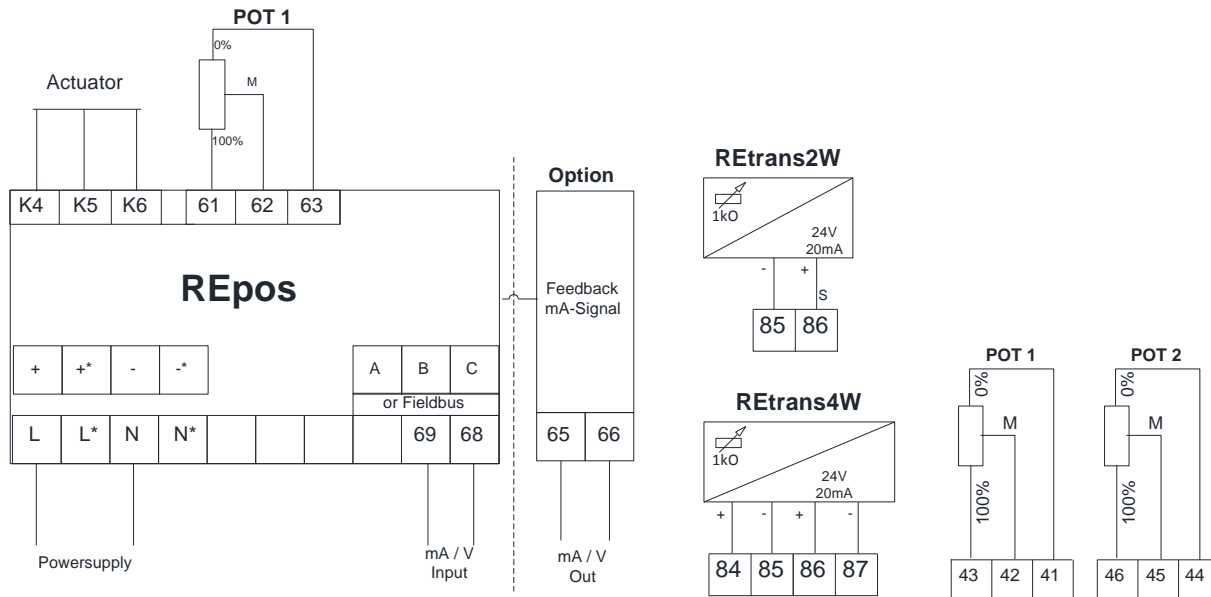

Figure 41: Standard connection plan REAct 30 accessories

Table 15: Connection diagram abbreviations REAct 30

K1	Force switch (open direction)
K2	Force switch (closed direction)
E1	Limit switch (open position)
E2	Limit switch (closed position)
E3	Limit switch (intermediate position)
E4	Limit switch (intermediate position)
Pot	Potentiometer
Hz	Heating element
REtrans	Position transducer
REpos	Digital valve positioner
C	Capacitor

9.5.2 Spare Parts REact 30

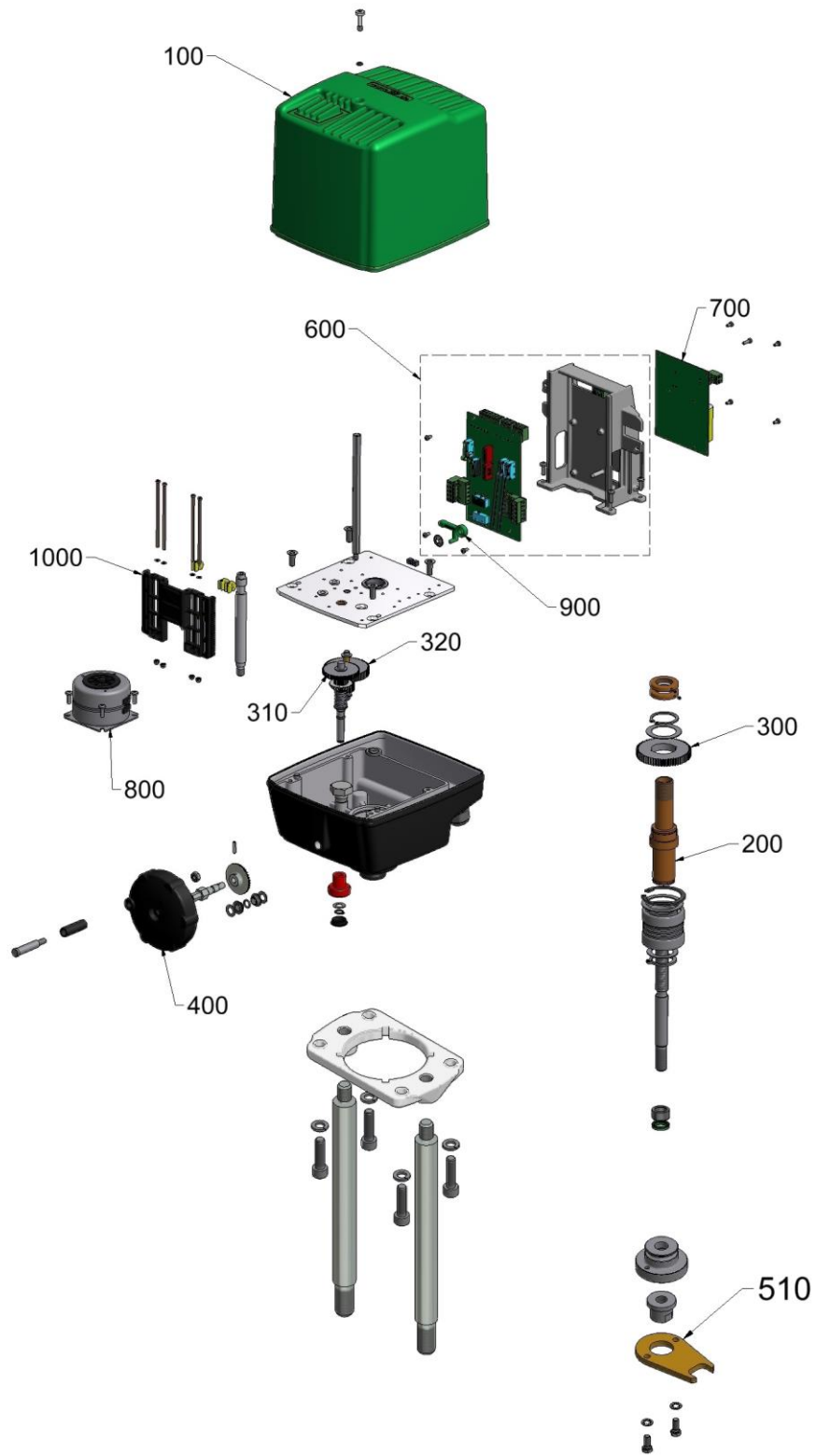

Figure 42: Explosion drawing REact 30 E with pillars

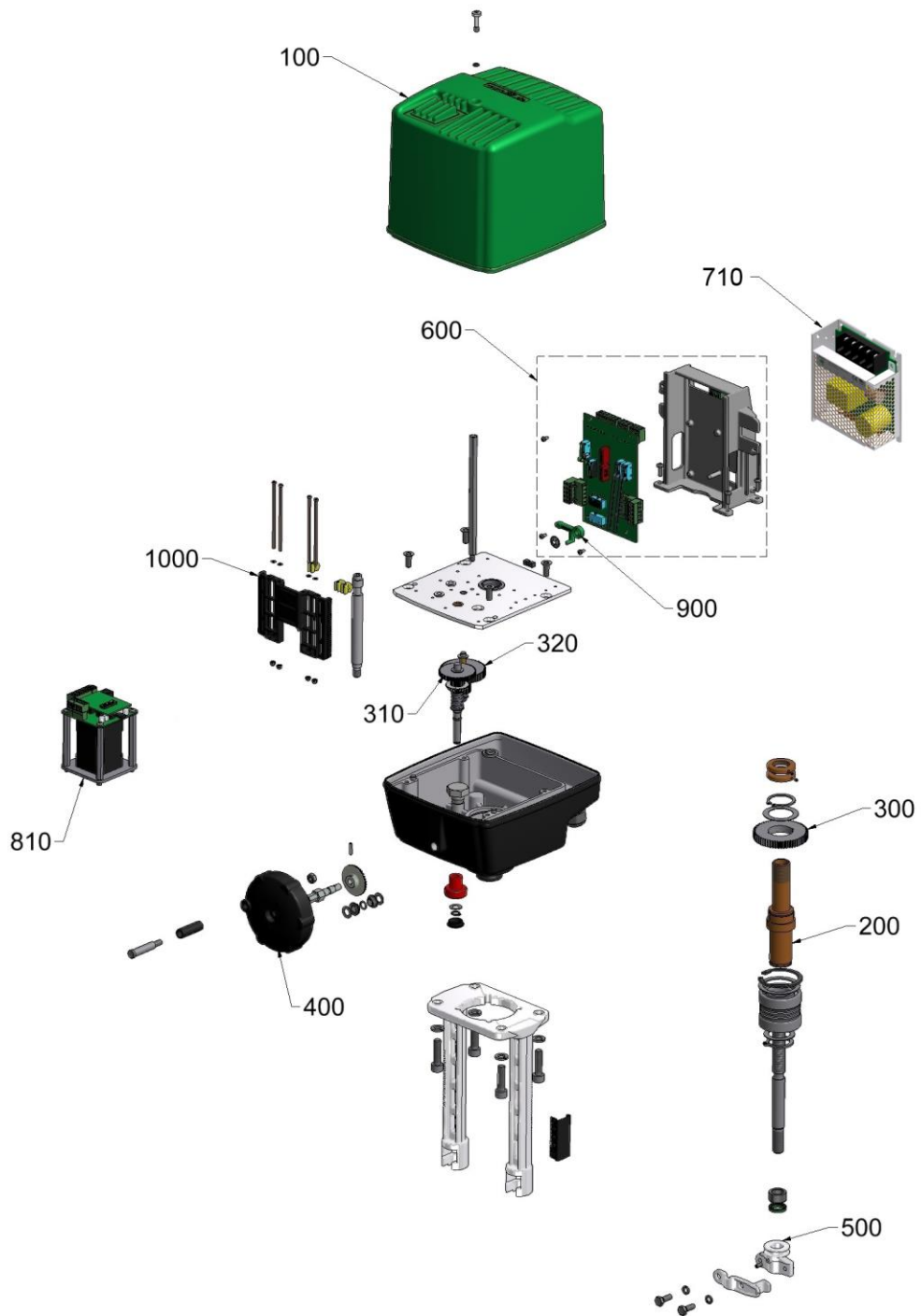

Figure 43: Explosion drawing REAct 30 DC with yoke

Table 16: Spare part list REact 30¹

Item	Item Description 1	Item Description 2	Part No.
100	Housing–upper part		CGEHR3000009
200	Stem nut group		CMUSR2000009
300	Gear group 0		CZRAR2000009
		DC	CZRAR2009009
310	Gear group 1		CZRAR3010009
		DC	CZRAR2019009
320	Gear group 2		CZRAR2020009
		DC	CZRAR2029009
400	Hand wheel group		CRAH3000009
500	Coupling group	Yoke	CKUKR1500009
510	Coupling group	Column	CKUKR1510009
600	Main terminal board group		CZELR3000009
700	Motor capacitor circuit board	230 V / 0,28 mm/s	CPLER201B109
		230 V / 0,74 mm/s	CPLER301B209
		230 V / 1,12 mm/s	CPLER301B309
		115 V / 0,28 mm/s	CPLER201D109
		115 V / 0,74 mm/s	CPLER301D209
		115 V / 1,12 mm/s	CPLER301D309
		24 V / 0,28 mm/s	CPLER201G109
		24 V / 0,74 mm/s	CPLER301G209
		24 V / 1,12 mm/s	CPLER301G309
710	Power supply unit	50 W / 24 V / 2,2 A	CNEG15360005
800	Synchronous-motor group	230 V / 0,28 mm/s	CMOTR20SB109
		230 V / 0,74 mm/s	CMOTR309B209
		230 V / 1,12 mm/s	CMOTR309B309
		115 V / 0,28 mm/s	CMOTR20SD109
		115 V / 0,74 mm/s	CMOTR309D209
		115 V / 1,12 mm/s	CMOTR309D309
		24 V / 0,28 mm/s	CMOTR20SG109
		24 V / 0,74 mm/s	CMOTR309G209
		24 V / 1,12 mm/s	CMOTR309G309
810	Direct-current-motor-group	24 V DC, BLDC	CMOTR154I009
900	Lever-power switch group		CHESR3000009
1000	Slide-group		CFFER3000009

¹ When ordering spare parts please state actuator type and serial number (see data plate). When ordering motors and capacitors please state power supply.

9.6 Actuator REact 60/100

9.6.1 Connection Plans REact 60/100

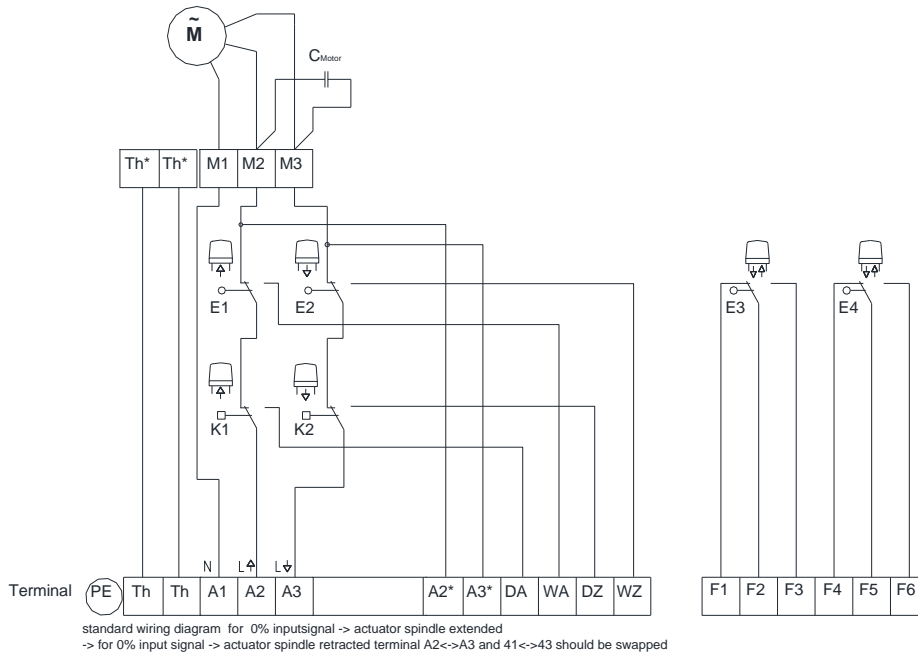

Figure 44: Standard connection diagram REact 60/100 E (Single Phase AC)

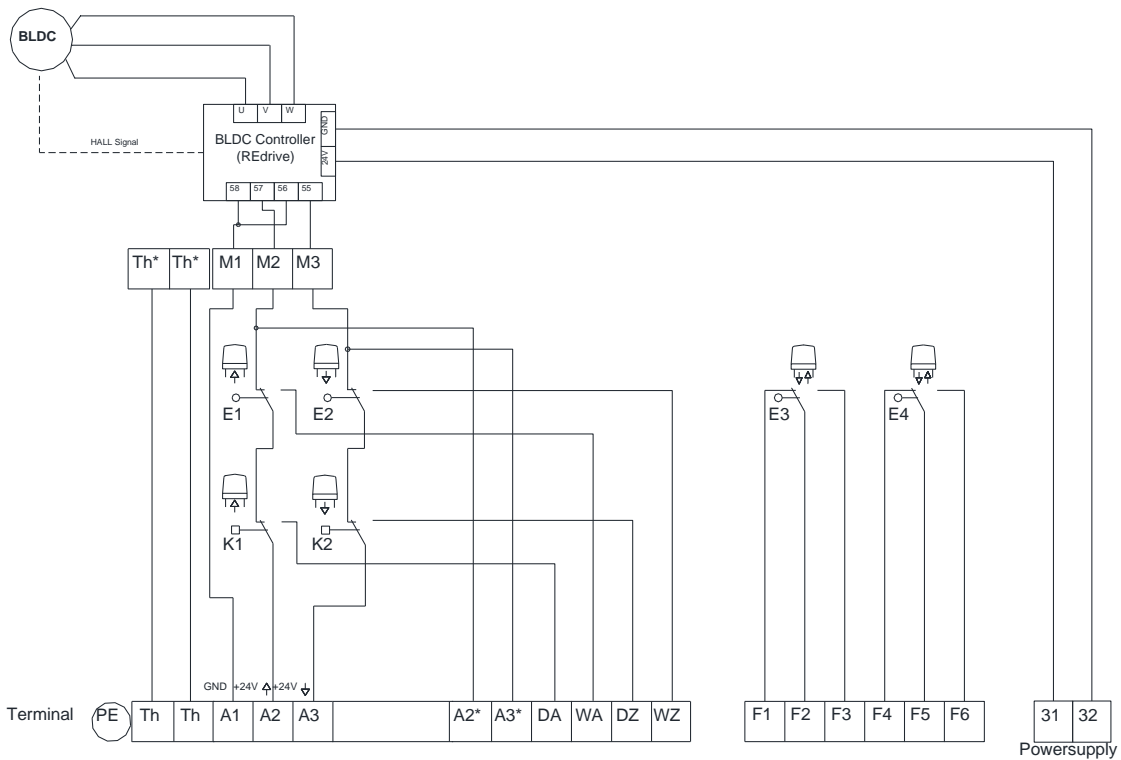

Figure 45: Standard connection diagram REact 60/100 DC

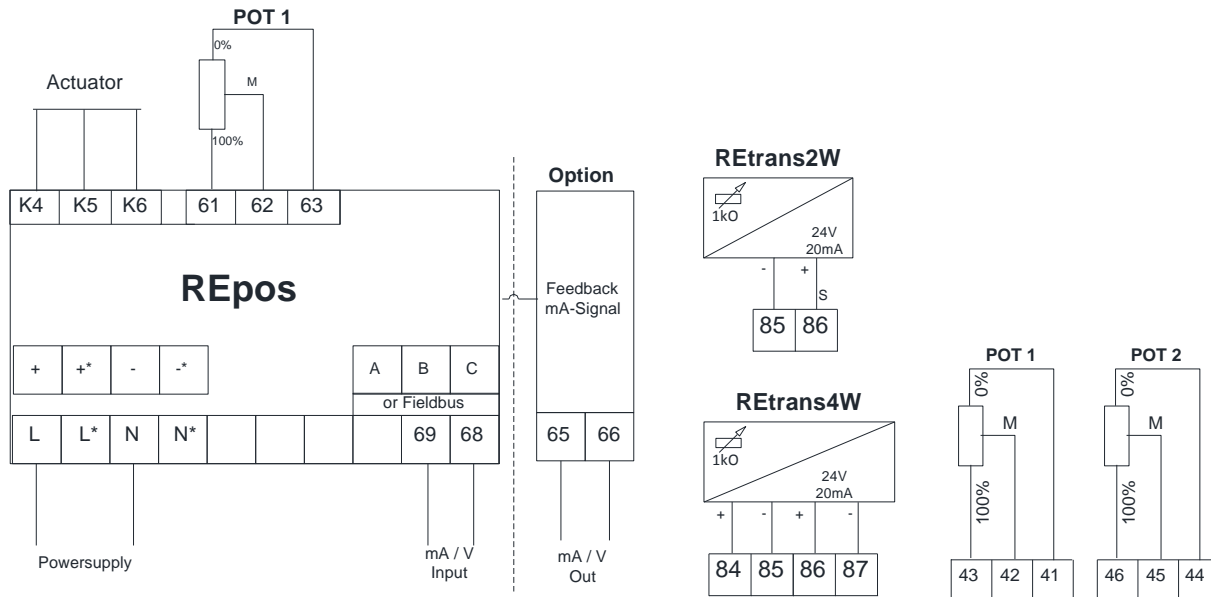

Figure 46: Connection plan REAct 60/100 accessories

Table 17: Connection diagram abbreviations REAct 60/100

K1	Force switch (open direction)
K2	Force switch (closed direction)
E1	Limit switch (open position)
E2	Limit switch (closed position)
E3	Limit switch (intermediate position)
E4	Limit switch (intermediate position)
Pot	Potentiometer
Hz	Heating element
REtrans	Position transducer
REpos	Digital valve positioner
C	Capacitor

9.6.2 Spare Parts REact 60/100

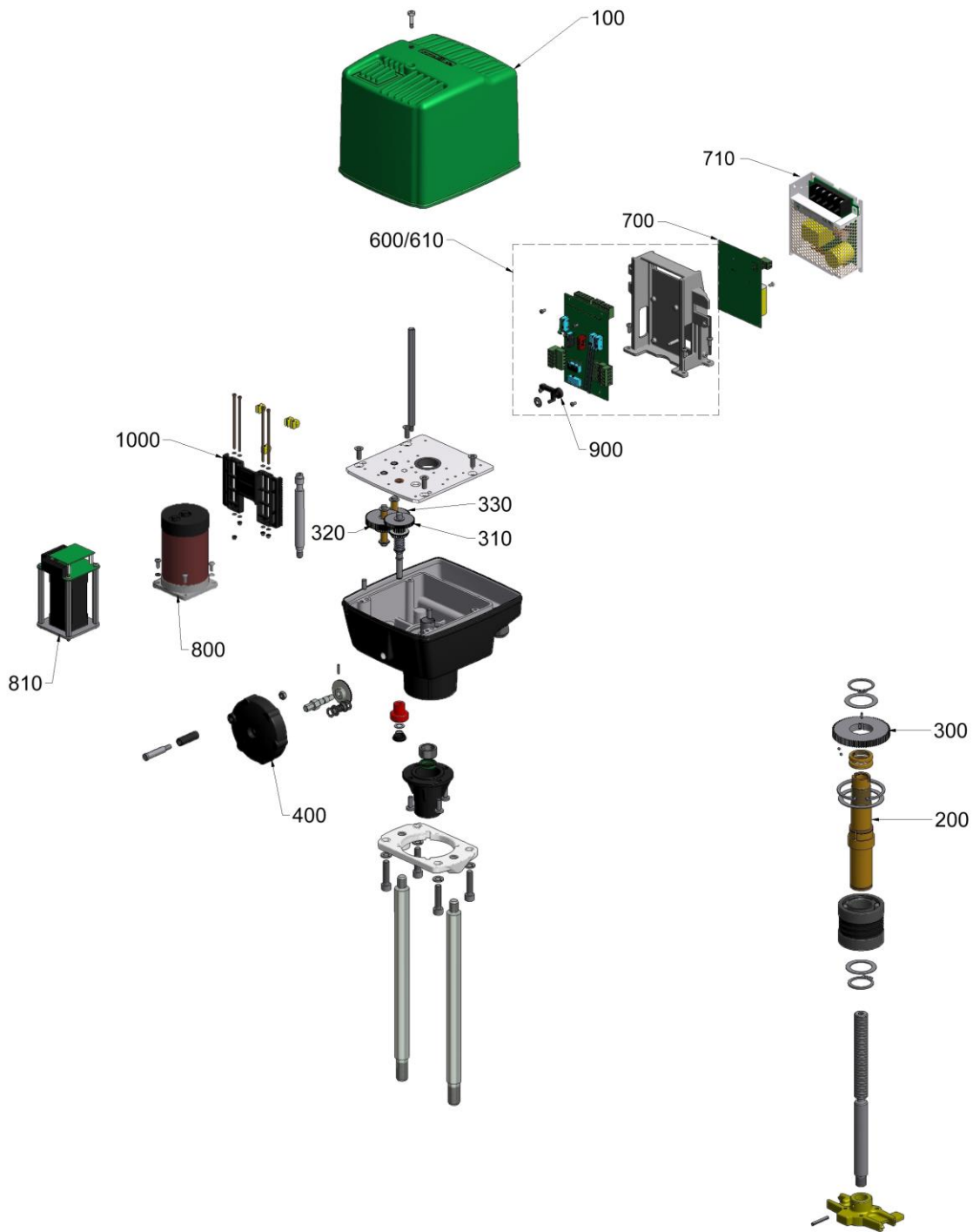

Figure 47: Explosion drawing REact 60/100 E/DC with stroke 60 mm

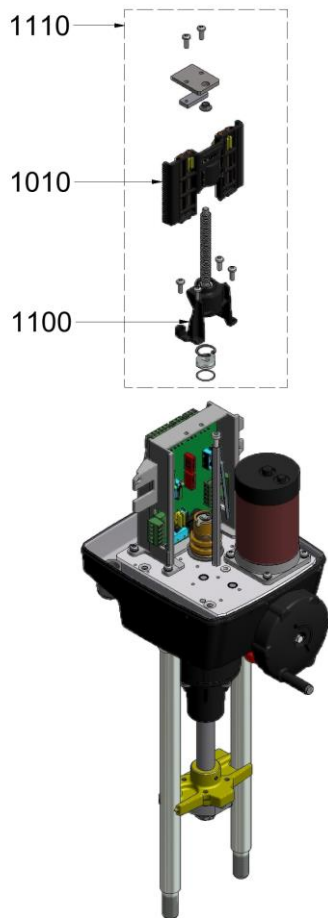

Figure 48: Explosion drawing REact 60/100 E with stroke 80 mm

Table 18: Spare parts list REact 60/100

Item	Item Description 1	Item Description 2	Part No.
100	Housing – upper part		CGEHR3000009
200	Stem nut group	REact 60	CMUSR3500009
		REact 100	CMUSR4500009
300	Gear group 0		CZRAR4000009
310	Gear group 1		CZRAR3010009
320	Gear group 2	0,30 mm/s; 0,45 mm/s	CZRAR4021009
		0,90 mm/s	CZRAR4022009
		1,7 mm/s	CZRAR4023009
330	Gear group 3	0,30 mm/s; 0,45 mm/s	CZRAR4031009
		0,90 mm/s	CZRAR4032009
		1,70 mm/s	CZRAR4033009
400	Hand wheel group		CRAH3000009

600	Main terminal board group		CZELR3000009		
610		230 V REact60 1,70 mm/s 230 V REact100 0,90 mm/s	CZELR4000009		
700	Motor capacitor circuit board	230 V REact60/100 0,30 mm/s	CPLER301B209		
		230 V REact60 0,90 mm/s 230 V REact60/100 0,45 mm/s	GPLER301B309		
		230 V REact60 1,70 mm/s 230 V REact100 0,90 mm/s	CPLER401B319		
		115 V REact60/100 0,30 mm/s	CPLER301D209		
		115 V REact60 0,90 mm/s 115 V REact60/100 0,45 mm/s	CPLER301D309		
		115 V REact60 1,70 mm/s 115 V REact100 0,90 mm/s	CPLER401D319		
		24 V REact60/100 0,30 mm/s	CPLER301G209		
		24 V REact60 0,90 mm/s 24 V REact60/100 0,45 mm/s	CPLER301G309		
		24 V REact60 1,70 mm/s 24 V REact100 0,90 mm/s	CPLER401G319		
		710	Power supply unit	50 W / 24 V / 2,2 A	CNEG15360005
		800	Synchronous-motor group	230 V REact60/100 0,30 mm/s	CMOTR309B209
				230 V REact60 0,90 mm/s 230 V REact60/100 0,45 mm/s	CMOTR309B309
230 V REact60 1,70 mm/s 230 V REact100 0,90 mm/s	CMOTR409B319				
115 V REact60/100 0,30 mm/s	CMOTR309D209				
115 V REact60 0,90 mm/s 115 V REact60/100 0,45 mm/s	CMOTR309D309				
115 V REact60 1,70 mm/s 115 V REact100 0,90 mm/s	CMOTR409D319				
24 V REact60/100 0,30 mm/s	CMOTR309G209				
24 V REact60 0,90 mm/s 24 V REact60/100 0,45 mm/s	CMOTR309G309				
24 V REact60 1,70 mm/s 24 V REact100 0,90 mm/s	CMOTR409G313				
810	Direct-current-motor-group			24 V DC, BLDC	CMOTR404I009
900	Lever-power switch group				CHESR3000009
1000	Slide-group				CFFER3000009
1010	Adaption-slide-group		CFFER4000009		
1100	Adaption-stem-group		CSPGR4000009		
1110	Adaption-stem- retrofit		CSPGR4010009		

9.7 Actuator ST 5106

9.7.1 Connection Plans ST 5106

Single Phase AC

Three Phase AC

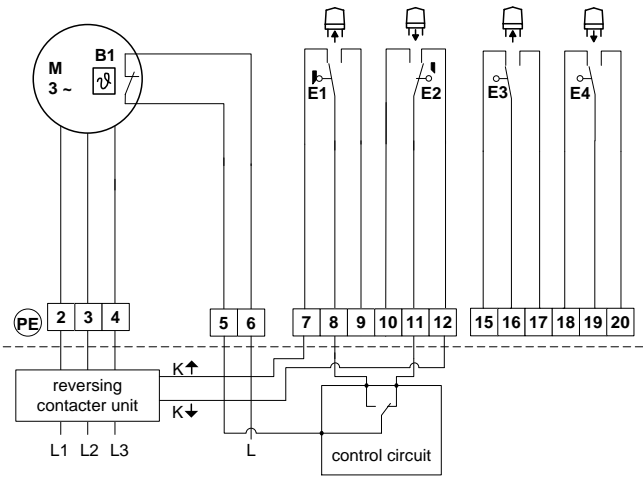
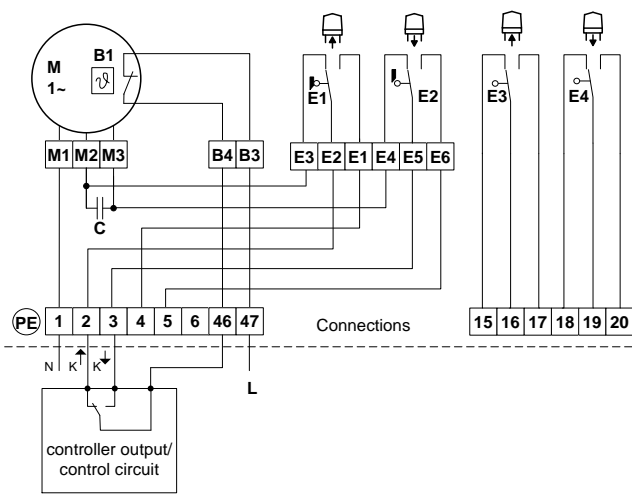

Figure 49: Standard connection diagram ST 5106-20/60

Single Phase AC

Three Phase AC

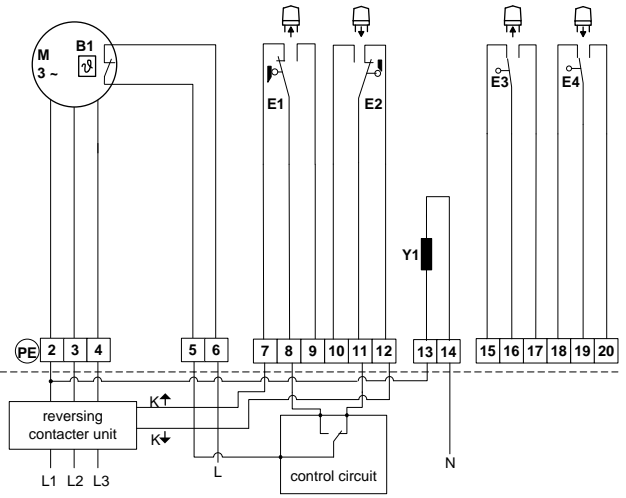
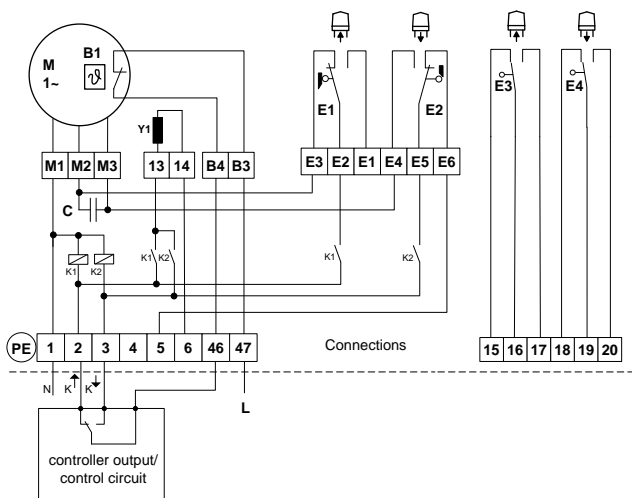

Figure 50: Standard connection diagram ST 5106-61

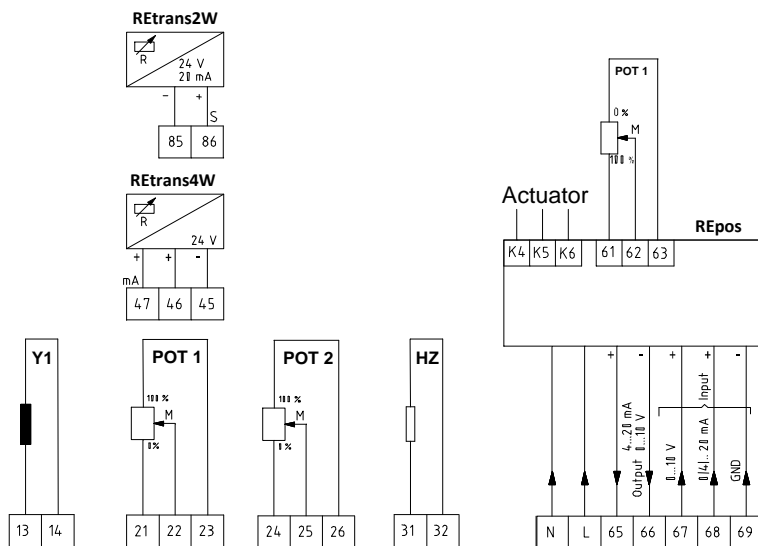

Figure 51: Standard connection diagram ST 5106 accessories

Table 19: Connection diagram abbreviations ST 5106

E1	Limit switch (open position)
E2	Limit switch (closed position)
E3	Limit switch (intermediate position)
E4	Limit switch (intermediate position)
Pot	Potentiometer
HZ	Heating element
REtrans	Position transducer
REpos	Digital valve positioner
C	Capacitor
K1	Brake control
K2	Brake control
B1	Integrated temperature switch
Y1	brake (only ST 5106-61)

9.7.2 Spare Parts ST 5106

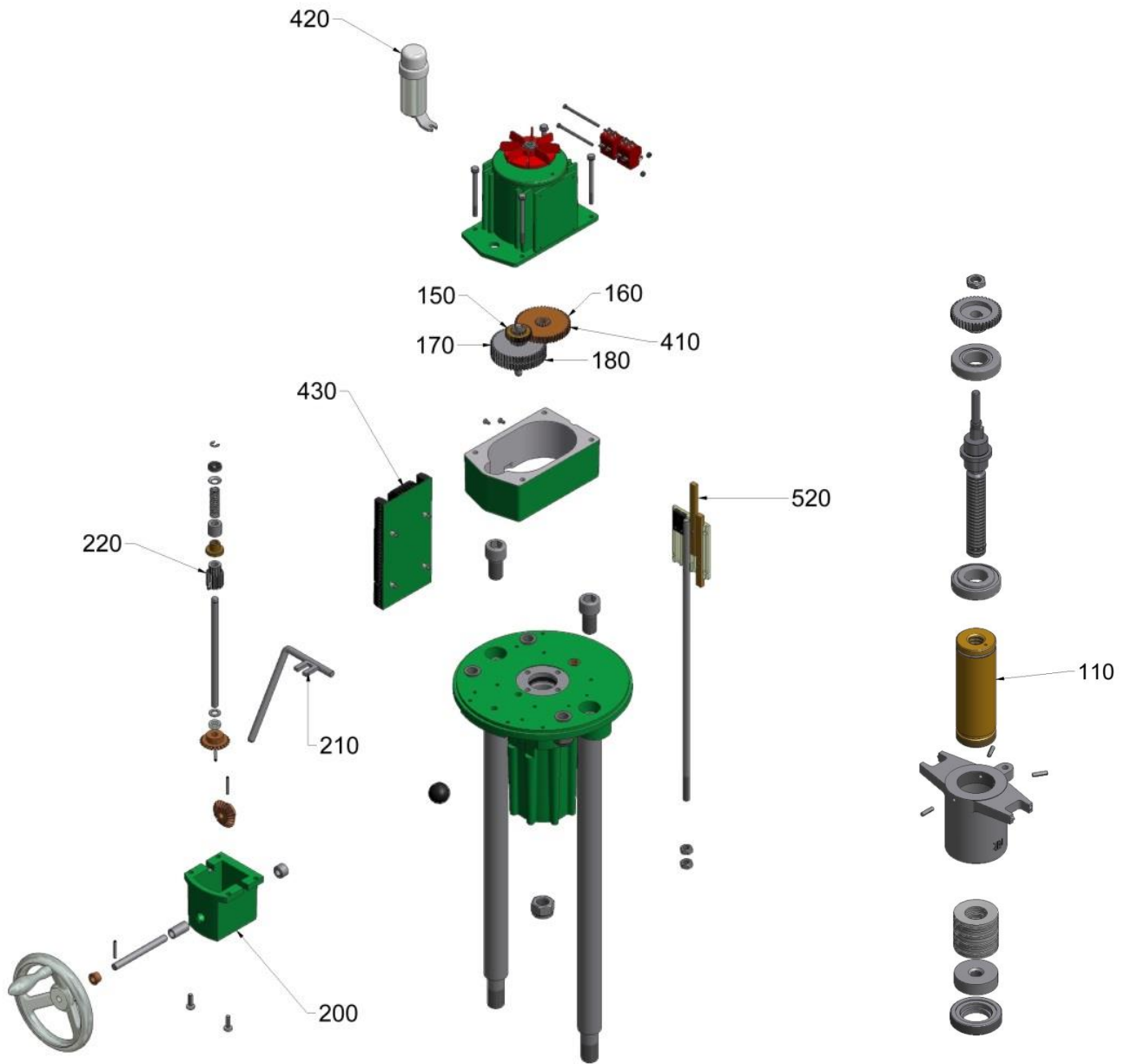



Figure 52: Explosion drawing ST 5106

Table 20: Spare part list ST 5106¹

Item	Item Description 1	Item Description 2		Part No.
050	cover			CADH51060009
110	stem nut group	-20 -60/-61		CSPT06000009 CSPT06000109
140	gear wheel 0			CZRA51060009
150	gear wheel 1			CZRA51061009
160	gear wheel 2			CZRA51062009
170	gear wheel 3			CZRA51063009
180	gear wheel 4			CZRA51064009
200	hand wheel housing			CKSH51060009
210	clutch lever			CHES51060009
220	Coupling shaft group			CWEK51060009
410	Motor plate group (motor + limit switch PCB)	-20/-60	230 VAC 400 V	CMOP06PB0009 CMOP06PJ0009
	Motor plate group (motor + brake + limit switch PCB)	-61	230 VAC 400 V	CMOP06PB1009 CMOP06PJ1009
420	capacitor	-20/-60 -61		EKDS... EKDS...
430	limit switch PCB	-20/-60 -61	230 VAC 230 VAC	CPLEDB000109 CPLEDB000209
440	motor brake			CBRE51060009
520	cam plate			CSTS06000009

¹ When ordering spare parts please state actuator type and serial number (see data plate). When ordering motors and capacitors please state power supply.

10 Troubleshooting

 **WARNING** Only trained and qualified personnel should carry out troubleshooting. Before beginning any work on the valve and/or actuator, ensure it is safe to do so. Make sure that the relevant pipeline is depressurized and the process medium drained, if necessary allow the control valve to cool down or warm up to ambient temperature prior to starting any work. Make sure that the supply air or power supply and control signals are disconnected or blocked to prevent any hazards that could be caused by moving parts.

For troubleshooting of the controlling devices and accessories see the instructions furnished by the manufacturer of these items.

For troubleshooting the valve and/or actuator check the following:

Check that the operating conditions have not changed and that the valve is correctly specified. If the operating conditions have changed or the valve is not correctly specified please contact your authorized CIRCOR representative.

If it is not readily apparent where the fault is, then the valve and actuator need disconnecting (refer to section 7.1) and each item can be checked separately.

10.1 Valves

Open the valve (refer to section 7.2) check that there is no foreign material lodged between seat ring and plug and also check especially when using a perforated plug that there is no foreign material trapped in the plug.

 **NOTE:** The bonnet gasket has to be replaced when reassembling the valve.

If the seat leakage is too high check that the seat ring and/or plug are not damaged. If they are, then relap them if possible (refer to section 7.4). If this is not possible then they need replacing (refer to section 7.3).

If the valve plug doesn't move and there is no foreign material inside the valve then contact your authorized CIRCOR representative.

If the stem packing is leaking, retightening or replacing of stem packing is required. Pure graphite stem packing can be retightened. The PTFE/Graphite and the Bellows Seal have to be replaced (refer to section 7.5).

10.2 Pneumatic Actuators

Check that the correct air supply is present, max. 87 PSI (6 bar) and check that the air supply is clean dry instrument air with no moisture, oil or dust. Check that the air supply is connected to the correct port on the actuator. Check that the correct input signal is present (if required). If a positioner is installed, please check the IOM from the manufacturer.

Check that the actuator doesn't leak and that the diaphragm is not damaged. To replace a damaged diaphragm refer to section 8.2.

If there is a solenoid valve check that the correct supply voltage is present and that the solenoid valve has been correctly installed (piping).

10.3 Electric Actuators

Check that actuator can be moved manually (using the handwheel). If not, then there is a mechanical problem, if yes then there is an electrical problem.

10.3.1 Mechanical Problem

Remove the cover over the gear wheels and check these for obvious signs of damage (missing teeth etc.). Replace any damaged gear wheels. If the gear wheels are not damaged then the stem nut needs replacing.

10.3.2 Electrical Problem

Check that the correct supply voltage and control signal (if required) are present. Check that the limit switches have been correctly adjusted, if not re-adjust them (see document REpos-8010). Check that the motor rotates and that it rotates freely, if not it needs replacing. Check that the internal wiring is correct (refer to standard connection plans in section 9, or connection plans in document REpos-8010). If unresolved, contact your authorized CIRCOR representative.

If there is a digital valve positioner and the red error LED is lit then refer to document REpos-8010.



CIRCOR is a market-leading, global provider of integrated flow control solutions, specializing in the manufacture of highly engineered valves, instrumentation, pipeline products and services, and associated products, for critical and severe service applications in the oil and gas, power generation, process, aerospace, and defense industries.

Excellence In Flow Control

Asia | Europe | Middle East | North America | South America



Designed and manufactured in Germany



Assembled and supported in the US & Canada

**South East USA
Mec-Tric Control Ltd.**

Chris Bucki
4110 Monroe Rd.
USA Charlotte, NC 28205
Phone: +1 704 376 8555
e-mail: sales@mec-tric.com
www.mec-tric.com

**North East &
Mid Atlantic USA**

Leonard Powers Inc.
442 W, 49th Street
USA- New York NY 10019
Phone: +1 21 2244 8878
e-mail: keith@leonardpowers.com
www.leonardpowers.com

**Upper Mid-West &
North-Central USA
KEI Steam Solutions Inc.**

3140 Lowell Drive
USA WI 54311 Green Bay
Phone: +1 920 465 4130
e-mail: sales@keisteam.com
www.keisteam.com

**Lower Mid-West &
South-Central USA
Control Products Inc.**

Dr. Headland 1668
USA Fenton, MO 63026
Phone: +1 800 583 6896
e-mail: sales@cpinc.com
www.cpinc.com

West USA

Bermingham Controls
11144 Business Circle
USA Cerritos, CA 90703- 5523
Phone: +1 562 860 1600
e-mail: sales@bermingham.com
www.bermingham.com

Canada

Great Lakes Industrial Controls
880 Upper Canada Drive
Sarnia, Ontario | N7W 1A4
Phone: (800) 546-0705'
e-mail: sales@greatlakesic.com
www.greatlakesic.com



Max-Planck-Strasse 3
D-70806
Kornwestheim, Germany
rtk@circor.com

circor.com | rtk.de